



BADU[®]

90/500 DS

Dual speed energy efficient pool and pool heating pump



Includes: Dual Speed Switch



The more stars the more energy efficient

ENERGY RATING

A joint government and industry program
Special Rating Method (SRM) 100 (100%)
(Class 1000)

Efficiency (%)	Flow Rate (l/min)	Head (m)	Power (kW)	Noise (dB)
29.2	139.5	3	266	

Energy consumption
625
kWh per year
To pump 50,000 litres/day

Where used in accordance with AS 1022
Actual energy use and heating costs will depend on local use and the system.

Compare models at www.energyrating.gov.au

SPECK X
pumpen

6-Star Energy Rating

Flow Rate up to 465 lpm
on High Speed

Quieter, smoother performance

German design & engineering

5 Year Warranty*

Robust 2.0 HP motor

Easy to remove non-corrosive lid with handle



BADU[®]

90/500 DS

The Speck 90/500 DS is the ideal choice for all domestic pool and pool heating applications where high flow rates are required.

Features:

- A high resistance to corrosion and salt water
- The ultimate in reliability
- No contact between motor and pump shaft with pool or spa water
- Highest quality mechanical seal
- Fan cooled - suitable for high ambient temperatures
- Closed impeller
- Stainless steel motor shaft
- Easy to remove clear strainer lid
- Every pump factory wet tested for quality control

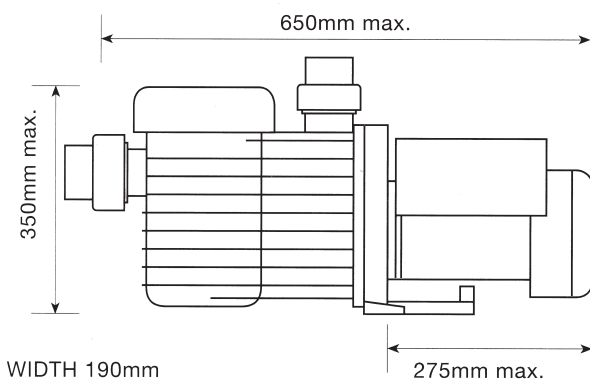
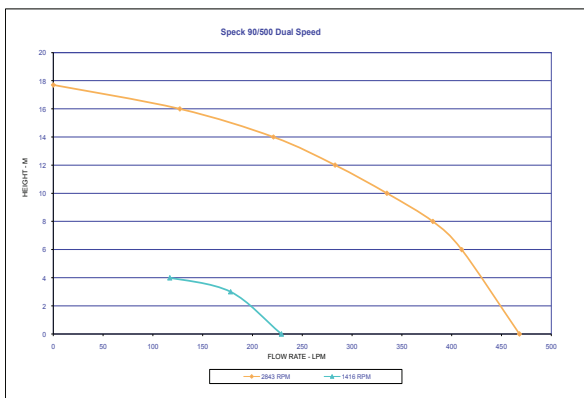

Optional LED Lid Light also available

See what's happening in your pool pump basket – even in the dark

- LED Brilliance
- Up to 5 year battery life
- Replaceable battery
- Larger basket collects more debris

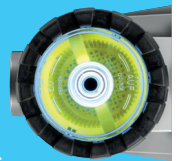

	90/500DS
Head Max/Min - m	18/2
Inlet Connection - mm	50
Outlet Connection - mm	40
Motor Speed - RPM	H 2800/L 1420
Power Input - V	240
Power Output - watts	H 1180/L 140
AMPS	H 6.5/L 1.2
Weight - kg	22
Max Water Temp - Deg.C	40

WARRANTY

* Five (5) Year Factory Warranty on the following wet end components: Casing, Diffuser, Gland Housing, Impeller and Mechanical Seal. Two (2) Year Warranty on motor and in all commercial applications. The pouring of salt and chemicals directly into the skimmer box will void full warranty.



1300 166 253 for Sales and Service
 e sales@continentalwater.com.au / accounts@continentalwater.com.au ABN: 71 050 287 735

New South Wales Office
 t (02) 8814 2800
 f (02) 9838 7030

Victorian Office
 t (03) 8794 3800
 f (03) 9702 3941

Queensland Office
 t (07) 3434 1100
 f (07) 3219 2266

New Zealand Office
 t 0011 64 9570 9570
 f 0015 64 9527 7641