

DAVEY

DAVEY Lifeguard

Complete Pool Chlorination & Chemistry Control System

Model: DCLGAU

Installation and Operating Instructions



WARNING: Failure to follow these instructions and comply with all applicable codes may cause serious bodily injury and/or property damage.

The installation of this product should be carried out by a person knowledgeable in swimming pool plumbing requirements following the installation instructions provided in this manual. Always ensure you're working from the current revision of this manual. Refer to www.bit.ly/AULifeguard

CONTENTS:

1. PACKING LIST	4
2. IMPORTANT SAFETY INSTRUCTIONS	5
3. COMMON TERMS	5
4. INSTALLING THE NEW DAVEY LIFEGUARD	6
4.1. TOOLS REQUIRED	6
4.2. INSTALLATION OF THE NIPPER	6
4.3. THE ACID DOSING PUMP	6
4.3.1. COMPONENTS OF THE ACID DOSING PUMP	6
4.3.2. GENERAL INFORMATION ABOUT THE ACID DOSING PUMP	7
4.3.3. MOUNTING THE ACID DOSING PUMP	7
4.3.3.1. INSTALLATION WITH THE PROVIDED BRACKET:	7
4.3.3.2. SUCTION FILTER INSTALLATION:	8
4.3.3.3. SQUEEZE TUBE REPLACEMENT:	8
4.4. INSTALLATION OF THE PROBE & INJECTION POINT HOUSING	9
4.4.1. COMPONENTS OF THE PROBE & INJECTION POINT HOUSING	9
4.4.2. GENERAL INFORMATION ABOUT THE PROBE & INJECTION POINT HOUSING	9
4.4.3. PLUMBING THE PROBE & INJECTION POINT HOUSING	9
4.4.4. WATER DRAINING FROM PROBE & INJECTION POINT HOUSING	10
4.4.5. PLUMBING THE PROBE & INJECTION POINT HOUSING TO ACID DOSING PUMP	11
4.4.6. WIRING THE ACID DOSING PUMP TO THE DAVEY LIFEGUARD CONTROLLER	12
4.4.7. PLUMBING PROBE BLANKS INTO PROBE AND INJECTION POINT HOUSING:	12
4.5. PROBE CONNECTIONS	13
4.5.1. PH PROBE	13
4.5.2. ORP PROBE	13
4.5.3. TEMPERATURE SENSOR AND TDS PROBE	14
4.6. THE DAVEY LIFEGUARD CONTROLLER	14
4.6.1. POWERING THE DAVEY LIFEGUARD CONTROLLER	14
4.6.2. DAVEY LIFEGUARD COMMUNICATION LEAD TO NIPPER	15
4.6.3. DAVEY LIFEGUARD COMMUNICATION LEAD TO NIPPER	16
4.6.4. CONNECTING LIFEGUARD TO PM400BT	16
5. CONTROL PANEL	17
5.1. LAYOUT	17
6. FIRST TIME START-UP PROCEDURE	17
6.1. LANGUAGE MENU	17
6.2. CLOCK FORMAT MENU	18
6.3. CLOCK MENU	18
6.4. POOL VOLUME MENU	19
6.5. PH PROBE MENU	19
6.6. ORP PROBE MENU	24
6.7. SALT PROBE MENU	26
6.8. TEMP PROBE MENU	27
7. CONNECTING DAVEY LIFEGUARD TO WIFI	27
7.1. FIRMWARE UPDATES	28
7.2. WiFi CONNECTION	29
8. OPERATIONAL INSTRUCTIONS	29
8.1. pH CONTROL	29
8.1.1. ADJUSTING PH SET POINT	30
8.1.1.1. ON THE DAVEY LIFEGUARD CONTROL PANEL	30

8.1.1.2.	USING THE APP	31
8.1.2.	RE-CALIBRATING PH PROBE	33
8.1.2.1.	ON THE DAVEY LIFEGUARD CONTROL PANEL	33
8.1.2.2.	USING THE APP.....	34
8.1.3.	OVERRIDING/IGNORING PH PROBE	34
8.1.3.1.	ON THE DAVEY LIFEGUARD CONTROL PANEL.....	34
8.1.3.2.	USING THE APP.....	36
8.2.	ORP/CHLORINE CONTROL	37
8.2.1.	ADJUSTING ORP SET POINT	38
8.2.1.1.	ON THE DAVEY LIFEGUARD CONTROL PANEL.....	38
8.2.1.2.	USING THE APP.....	40
8.2.2.	RE-CALIBRATING ORP PROBE.....	42
8.2.2.1.	ON THE DAVEY LIFEGUARD CONTROL PANEL.....	42
8.2.2.2.	USING THE APP.....	43
8.2.3.	OVERRIDING/IGNORING ORP PROBE.....	43
8.2.3.1.	ON THE DAVEY LIFEGUARD CONTROL PANEL.....	44
8.2.3.2.	USING THE APP.....	45
8.3.	SALT LOW WARNING.....	47
8.4.	SALT LOW ALARM.....	47
9.	ADVANCED FEATURES.....	47
9.1.	VSD SET POINT.....	48
9.1.1.	ADJUSTING VSD SET POINT ON DAVEY LIFEGUARD CONTROL PANEL.....	48
9.2.	SYSTEM MODE	49
9.2.1.	ACTIVATING SYSTEM MODE ON DAVEY LIFEGUARD CONTROL PANEL.....	50
9.2.2.	ACTIVATING SYSTEM MODE ON DAVEY APP	51
9.3.	SCHEDULE MODE.....	52
9.3.1.	ADJUSTING SYSTEM MODE ON DAVEY LIFEGUARD CONTROL PANEL	52
9.3.1.1.	ADDING A TIMER.....	52
9.3.1.2.	ACTIVATING SCHEDULE MODE.....	54
9.3.2.	ADJUSTING SCHEDULE MODE ON DAVEY APP	56
9.3.2.1.	ADDING A TIMER.....	56
9.3.2.2.	REMOVING A TIMER	58
9.3.2.3.	ACTIVATING SCHEDULE MODE.....	59
9.4.	BOOST MODE.....	60
9.4.1.	ACTIVATING BOOST MODE ON DAVEY LIFEGUARD CONTROL PANEL.....	60
9.4.2.	ACTIVATING BOOST MODE ON DAVEY APP	62
9.5.	WINTER MODE	63
9.5.1.	ACTIVATING WINTER MODE ON DAVEY LIFEGUARD CONTROL PANEL	64
9.5.2.	ACTIVATING WINTER MODE ON DAVEY APP.....	65
9.6.	SERVICE MODE	67
9.7.	BACKWASH MODE.....	67
9.7.1.	ADJUSTING BACKWASH MODE ON DAVEY LIFEGUARD CONTROL PANEL.....	67
9.7.2.	ADJUSTING BACKWASH MODE ON THE APP.....	69
9.8.	SPA MODE (FOR USE IF NO ORP PROBE IS CONNECTED).....	69
9.8.1.	ACTIVATING SPA MODE ON DAVEY LIFEGUARD CONTROL PANEL.....	69
9.8.2.	ACTIVATING SPA MODE ON DAVEY APP	70
9.9.	COVER MODE (FOR USE IF NO ORP PROBE IS CONNECTED).....	72
9.9.1.	ACTIVATING COVER MODE ON DAVEY LIFEGUARD CONTROL PANEL.....	72

9.9.2.	ACTIVATING COVER MODE ON DAVEY APP	74
9.9.3.	ACTIVATING COVER MODE REMOTELY	75
9.10.	SPA & COVER MODE (SIMULTANEOUS)	76
9.11.	HEAT PUMP CONNECTION – “DAVEY HEAT PUMP”	76
9.11.1.	CONNECTING LIFEGUARD TO A “DAVEY HEAT PUMP”	76
9.11.2.	CONNECTING LIFEGUARD TO A “DAVEY NIRVANA HEAT PUMP”	79
9.11.3.	ADJUSTING SET TEMPERATURE OF HEAT PUMP VIA LIFEGUARD	82
10.	GENERAL INFORMATION	84
10.1.	RECOMMENDED POOL WATER LEVELS	84
10.2.	FACTORS THAT INFLUENCE YOUR POOL WATER CHEMISTRY	85
10.2.1.	CYANURIC ACID	85
10.2.2.	SODIUM BICARBONATE	85
11.	MAINTENANCE	86
11.1.	PROBE DAMAGE	86
11.2.	WINTERISING THE PROBES	86
12.	TROUBLESHOOTING	87
12.1.	WARNINGS AND ALARMS	87
12.2.	RECOVERING DRY PROBES	88
12.3.	ADDITIONAL TIPS	88
13.	SPARE PARTS	92
13.1.	EXPLODED DIAGRAM.....	92
13.2.	PARTS LISTING	92

1. PACKING LIST

- | | |
|-------------------------------------|---|
| A. 2 x 40/50mm unions; | J. 1 x Acid feed injection point; |
| B. 1 x QRG (Quick Reference Guide); | K. 1 x Probe and injection point housing; |
| C. 1 x Incoming power lead; | L. 1 x RJ45 connection cable; |
| D. 1 x Davey Lifeguard controller; | M. 4 x pH calibration solution; |
| E. 1 x Acid dosing pump kit; | N. 4 x ORP calibration solution; and |
| F. 1 x Antenna; | O. 1 x TDS calibration solution |
| G. 1 x pH probe; | P. 1 x pump connection cable |
| H. 1 x ORP probe; | Q. Wall plug and screw kit. |
| I. 1 x Salt/temperature probe; | |



2. IMPORTANT SAFETY INSTRUCTIONS



ATTENTION: Before carrying out any operation on the equipment, disconnect the power supply. Any and all electrical work installing, servicing or decommissioning should be handled by suitably qualified personnel.

3. COMMON TERMS

- **Acid:** A chemical compound that lowers pH by contributing hydrogen ions to a water solution.¹
- **Acid dosing pump:** Peristaltic pump to provide measured amounts of acid to the pool water to facilitate pH correction by lowering pH.
- **Alkaline (a.k.a. Base):** A chemical that neutralises solids, usually by furnishing hydroxyl ions (OH⁻). The opposite of an acid.¹
- **Balanced Water:** The correct ratio of hardness, alkalinity, temperature, dissolved solids, and pH that prevents pool water from being either corrosive or scale forming.¹
- **Calcification:** Formation of calcium carbonate scale on pool walls or the surface of circulation system components due to the precipitation of calcium carbonate.¹
- **Calcium Hardness:** The calcium portion of the total hardness. The level of calcium determines whether water is overly soft (too little) or hard (too much). Excessively high hardness levels may cause cloudy water and scale. Excessively low levels may harm the pool.¹
- **Calibration:** The process of checking or adjusting (by comparison with a standard) the accuracy of a measuring instrument.¹
- **Chlorine:** A common oxidiser used as a disinfectant and algicide in swimming pools.
- **Cyanuric Acid (C₃N₃O₃H₃) (a.k.a. Stabiliser):** A chemical that restricts the loss of chlorine because of ultra-violet rays from sunlight.
- **Hardness (water):** Refers to the quantity of dissolved minerals, chiefly calcium and magnesium compounds in the water. May be measured as Total Hardness (TH) or Calcium Hardness (CH). Not to be confused with Total Dissolved Solids (TDS) which is different.
- **Hydrochloric Acid (HCl) (a.k.a. Muriatic Acid):** A strong acid used to reduce the pH and total alkalinity as well to clean scale or acid wash surfaces. It is also generated in the reaction of chlorine gas and water.¹
- **Hypochlorous Acid (HOCl):** An unstable acid with excellent bactericidal and algicidal properties. The active agent by which chlorine serves as a disinfectant. It is in dynamic equilibrium with hypochlorite ion (OCl⁻), dependant on the pH of the water.¹ The equilibrium value where HOCl and OCl⁻ are equal is at pH of 7.5. The correct pH in pool water is very important to ensure chlorine is able to disinfect efficiently.
- **ORP (a.k.a. Oxidation Reduction Potential):** A method of measuring the potential, which often relates to the concentration of an oxidiser in the water.¹ In swimming pools this is generally measuring the chlorine available for use as an oxidiser. When measured by a probe the value should normally be 650mV but may vary by ±15mV. Too high indicates too much chlorine while too low indicates chlorine levels are low.
- **pH:** A measure of the degree of acidity or alkalinity of a solution. A pH of below 7.0 is considered acid. A pH above 7.0 is considered alkaline.¹ The pH of humans is between 7.35 and 7.45, i.e. slightly alkaline.
- **Probe (a.k.a. Sensor or Electrode):** A device placed in the pool water piping system that measures specific water properties. The measurements provided are interpreted by the Davey Lifeguard controller to either take corrective action or to initiate an alarm or warning that action is required.
- **Re-climatizing probes:** the process of reinstating probes to their normal operating condition after being allowed to dry out.
- **Total Alkalinity:** A measure of the ability of the water to maintain a desirable pH when acid is added to the water.¹
- **Total Dissolved Solids: (a.k.a. TDS)** refer to any minerals, salts, metals, cations or anions and some, usually small amounts, of organic matter that are dissolved in water. Total dissolved solids (TDS) in a pool commonly reflects the salt levels in the water. This can be measured with a conductivity probe.
- **Total Hardness (TH):** The total of all calcium hardness and magnesium hardness in water.¹

Ref: 1: National Swimming Pool Foundation Pool and Spa Operators Handbook 2017

4. INSTALLING THE NEW DAVEY LIFEGUARD

4.1 TOOLS REQUIRED

- Cordless drill;
- 6mm drill bit;
- 7/32" wood drill bit;
- # 2 Phillips head screwdriver;
- Cable ties;
- 5L HCl acid;
- Chemical handling PPE (see section 4.3);
- 20L container suitable for use with HCl acid storage;
- Clippers, or knife to cut acid feeder tube;
- Hacksaw;
- Teflon "plumber's" tape;
- PVC primer; and
- PVC glue.

4.2 INSTALLATION OF THE Nipper

In order to operate, the Davey Lifeguard requires first, the installation of an Nipper. If this is yet to be fitted, please refer to the instructions supplied with the Nipper. An electronic copy of the full installation & operating instructions can be downloaded from the following URL www.bit.ly/nippercm, or by scanning this QR code.



IMPORTANT: If you are upgrading an already installed, existing Nipper it is important to connect your Lifeguard to WiFi after completing first time set-up so that the Nipper can receive a software update.

4.3 THE ACID DOSING PUMP

4.3.1. Components of the acid dosing pump



Figure 4.1

- A: Clear cover of acid dosing pump;
- B: 24VDC power lead;
- C: Acid feeder tube;
- D: Mounting screw;
- E: Wall plug for mounting screw;
- F: Double sided tape for assisted wall mounting;

G: Mounting bracket;
H: Locating lugs for clear cover of acid dosing pump;
I: Suction filter
J: Suction feeder tube drum weight;
K: Squeeze tube locking nuts, for acid feeder tube;
L: Squeeze tube;
M: Squeeze tube roller; and
N: Acid injection point fitting.

4.3.2. General information about the acid dosing pump



ATTENTION: If any of the instructions here contained is not respected, there can be damage to persons &/or incorrect working, or damage to the apparatus. Davey recommends the use of 5L HCl acid, added to 15L of tap water. This should be done in a container suitable of use with HCl acid. Do not use Sulphuric Acid. Suitable Personal Protective Equipment (PPE) should be worn during the process. Consult warnings on chemical containers where necessary.



ATTENTION: The acid drum should be located at least 2 metres from any other pool equipment. If the acid drum is located inside a room or an area with limited ventilation then a vent hole needs to be drilled in the lid and tubing run out to open area.

Davey recommends the use of low fuming pool acid.

Acid fumes will damage equipment and will not be covered by warranty.

The acid dosing pump needs to be installed a minimum of 2m away from the chemical drum, but no higher than 1.5m above it. When installing the pump, read the labels and verify the following:

- Tubing material is compatible with the liquid;
- The pressure at the injection point is lower, or equal to the pump nominal pressure;
- Acid (suction) feeder tubing is inserted in the liquid container, fitted to the suction connection of the pump (represented on the lid with \triangle) and tightened with the proper nut;
- Acid (delivery) feeder tubing is fitted to the delivery connection of the pump (represented on the lid with ∇), tightened with the proper nut;
- Allow sufficient length of feeder tubing to reach the proposed probe & acid dosing injection housing; and
- The locating lugs for the clear cover of acid dosing pump are correctly seated.



IMPORTANT: Davey recommends ensuring that all feeder tubing and probe cables be attached to pipework where possible. Use “cable ties” or “sticky/electrical tape”. This is good practice as it not only looks more professional, but also limits potential damage to feeder tubes and probe cables by becoming entangled, or pulled by users during servicing of equipment etc.

4.3.3. Mounting the acid dosing pump



ATTENTION:
Before carrying out any operation on the pump, disconnect the power supply.

The acid dosing pump needs to be installed a minimum of 2m away from the acid chemical drum (not included), but no higher than 1.5m above it.

4.3.3.1. Installation with the provided bracket:

- Fix the bracket with the provided screw;
- In case of tiled, or low friction walls, use the supplied adhesive tape as follows:
 - Peel off one of the two protective foils from the tape;
 - Stick the tape to the bracket;
 - Peel off the second protective foil; and
 - proceed to fix the bracket with the provided screw.
- Fix the pump on the bracket ensuring tongues on the back of the pump slides onto the bracket.

4.3.3.2. Suction filter installation:

- Feed the acid feeder tube through the lid of your acid container. A 7/32" drill bit is ideal to make this hole;
- Always ensure you drill a venting hole in the lid too (refer Figure 4.2). This is particularly important if the chemical container is stored in an unventilated area, as the venting port should be used to extract fumes from the area;
- Insert the end of the tubing in the weight so that it exits from the flared part (refer Figure 4.3);
- Insert the suction filter in the same end of the tubing (refer Figure 4.3);
- Replace the acid drum lid with the tube, weight and filter inside the drum. Allow for enough tube for the weight to sit at the bottom of the acid drum;
- It is strongly recommended to use the suction filter in all situations. It is the combination of the hose weight and suction filter that ensures that the acid tube intake does not suck itself flat against the bottom of the acid drum; and
- Clean it periodically to avoid dry residual of product, accumulation of dirt.



Figure 4.2

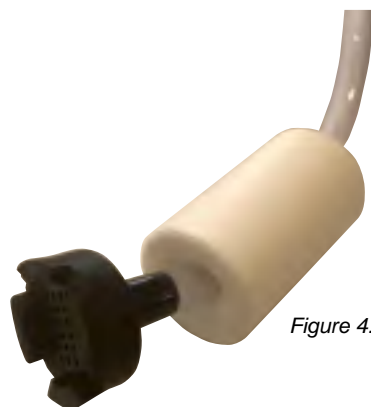

Figure 4.3

4.3.3.3. Squeeze tube replacement:

- Disconnect the pump from the power supply;
- Ensure that your circulation pump isn't running, or isn't about to run. For above ground pools (or pools where the water level is higher than the equipment) it may be necessary to close isolation valves to ensure water doesn't flood from the pool;
- Remove the clear cover of acid dosing pump;
- To remove the squeeze tube:
 - Turn the squeeze tube roller so that the roller is vertical;
 - Remove the feeder tube from its seated connection on the left of the pump. Alternately, pull the squeeze tube from its seat and manually rotate the squeeze tube roller clockwise until it is possible to extract the right-hand side connection from its seat.
- To fit the tube:
 - Turn the squeeze tube roller horizontally;
 - Insert the connection in its seat on the left of the pump with the curved side towards the floor. Alternately, push the tube into its seat and manually rotate the squeeze tube roller clockwise until it is possible to insert the right-hand side connection into its seat; and
 - Refit the clear cover of the acid dosing pump.

4.4. INSTALLATION OF THE PROBE & INJECTION POINT HOUSING

4.4.1. Components of the probe & injection point housing

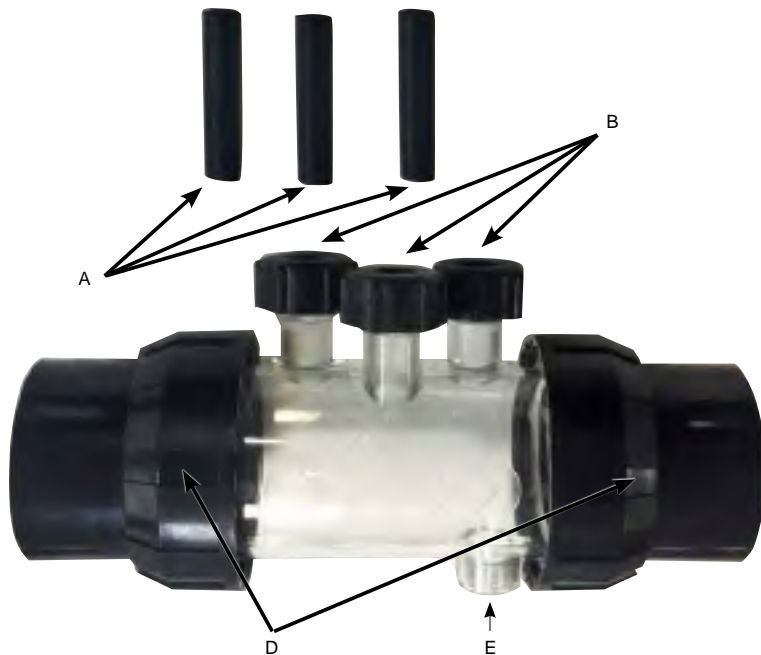



Figure 4.4

- A: 3 x probe sealing blanks;
- B: 3 x probe locking nut c/w o-ring & washer;
- C: Probe housing;
- D: 2 x barrel unions c/w tail, nut & o-ring; and
- E: Acid feed injection point.

4.4.2. General information about the probe & injection point housing

The probe housing comes with 3 x probe sealing blanks (labelled A in Figure 4.4). These will be useful for winterising the pool, or in the event of servicing. This will allow continued operation of the pool system, without the probe(s) fitted. Inside the 3 probe locking nuts (labelled B in Figure 4.4), there is an o-ring and washer for fitting each probe.

4.4.3. Plumbing the probe & injection point housing



IMPORTANT: When installing the probe & injection point housing, it is critical that the housing be installed correctly.

Ensure the following conditions are met:

- The housing is installed so the 3 probes insert into the housing from above. The acid injection point is underneath (refer Figure 4.5);

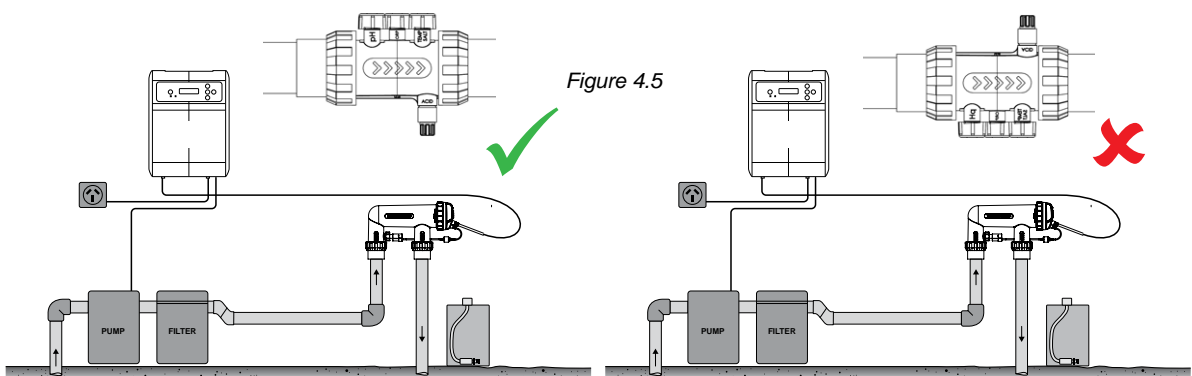

- The housing is installed so as water flow moves in the correct direction, shown by arrow markings on the housing (refer Figure 4.6);

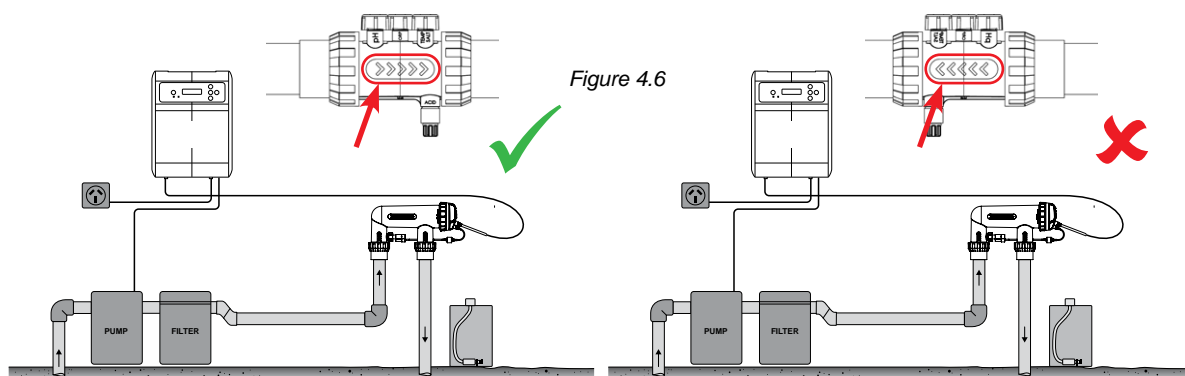

- The housing is installed horizontally (refer Figure 4.7);

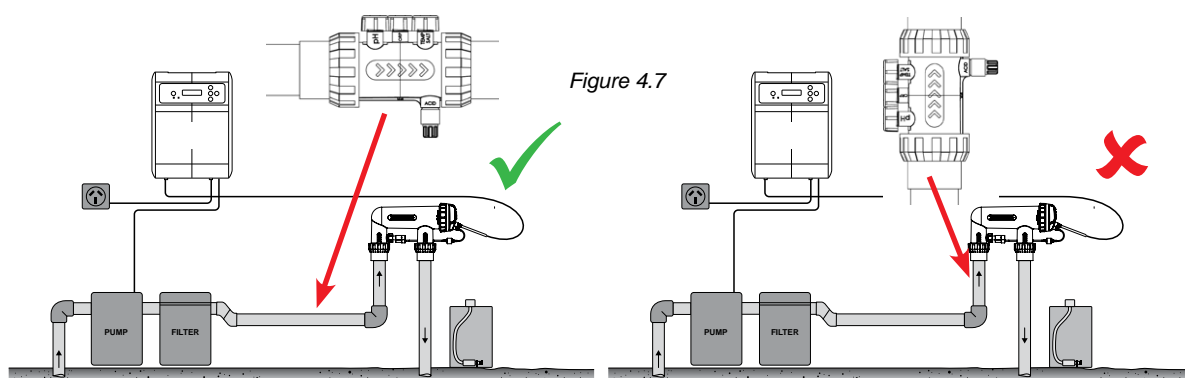

- The housing is installed up-flow of the Nipper cell housing (refer Figure 4.8);

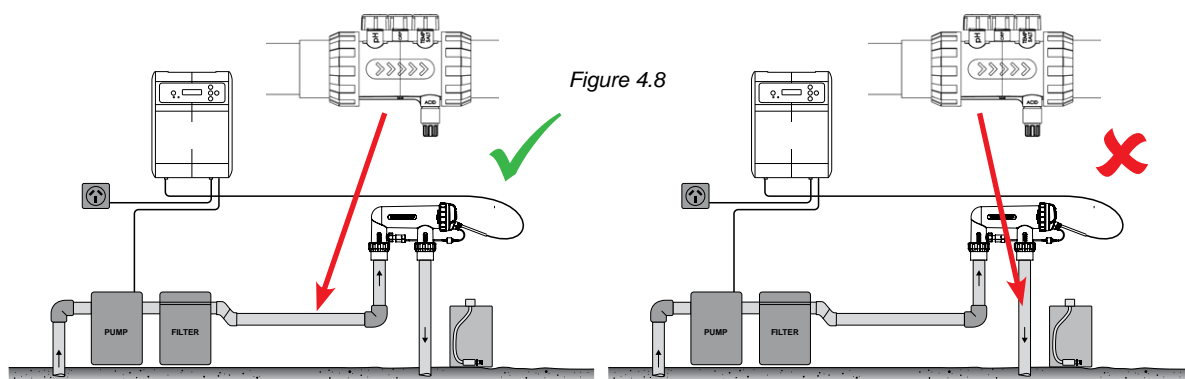

4.4.4. Water draining from probe & injection point housing



IMPORTANT: When installing the probe & injection point housing, the installation should ensure the probes remain wet, especially during the pump's off period.

If water is found to drain from pipework and especially from the probe and injection point housing, it is possible that the probes may dry out. Should this occur, please refer to the troubleshooting section that covers recovering dry probes. Where pipework is found to drain, the probe housing should be installed to allow a low point, to keep water in the housing, ensuring the probe ends remain submerged (refer Figure 4.9).

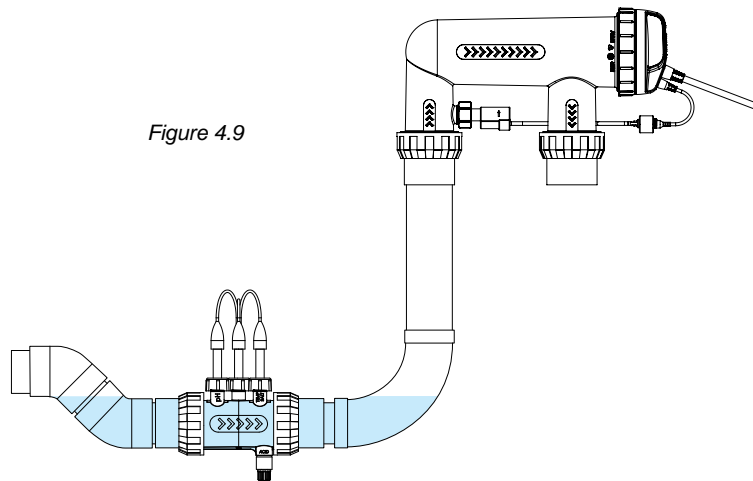

Figure 4.9

4.4.5. Plumbing the probe & injection point housing to acid dosing pump

Following section 4.2.2, the acid (delivery) feeder tubing should be fitted to the delivery connection of the pump (represented on the lid with ▽), and tightened with the locking nut.



IMPORTANT: Davey recommends ensuring that all feeder tubing and probe cables be attached to pipework where possible. Use “cable ties” or “sticky/electrical tape”. This is good practice, not only as the installation looks more professional, but it also limits potential damage to feeder tubes and probe cables by becoming entangled, or pulled by users during servicing of equipment etc.

- Screw the acid injection point, into the probe injection point housing (refer Figure 4.10). This will require plumbing thread tape only. **DO NOT USE SEALING COMPOUNDS, OR PIPE DOPE.**

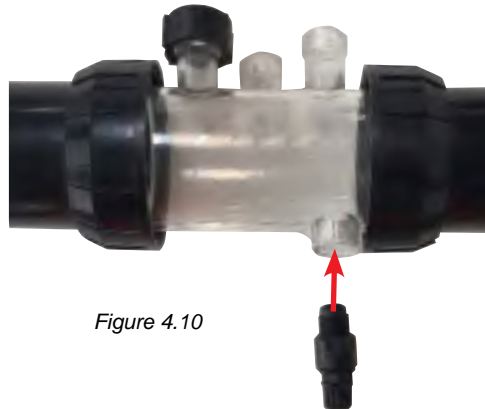

Figure 4.10

- Attach the other end of the acid injection point to the acid (delivery) feeder tubing and tighten the nut on the acid injection point (refer Figure 4.11).

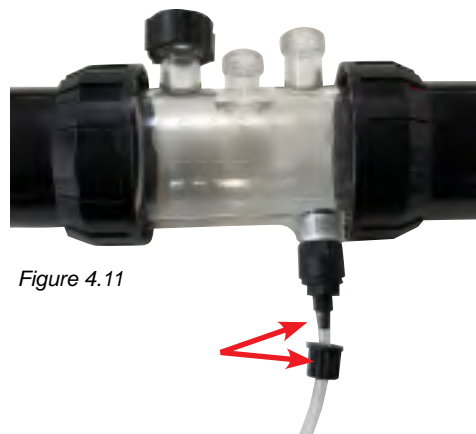

Figure 4.11

- Attach the other end of the acid (delivery) feeder tubing to the acid dosing pump and tighten nut (refer Figure 4.12).



Figure 4.12

4.4.6. Wiring the acid dosing pump to the Davey Lifeguard controller

The acid dosing pump is powered by an ELV (extra low voltage) 24VDC supply. On the end of the acid dosing pump power lead is a Tamiya connector (refer Figure 4.13).

The Tamiya connector needs to fit into the back of the Davey Lifeguard controller (refer Figure 4.13). The connector is deliberately designed such that it fits only one way.



Figure 4.13

4.4.7. Plumbing probe blanks into probe and injection point housing:

On the probe and injection housing, under each of the 3 x probe locking nuts, is an o-ring and washer (refer Figure 4.14). Remove the first probe locking nut on the housing (where it's marked pH);



Figure 4.14

- Carefully slide the probe locking nut, then the washer, then the o-ring, onto the probe blank (refer Figure 4.15);



Figure 4.15

- When sliding the blanking plug into the housing, ensure that the blank is located $\frac{1}{2}$ way into the probe housing (refer Figure 4.15);
- Hand tighten the probe locking nut onto the probe housing, that will in turn tighten the washer onto the o-ring (and create a seal). Repeat the process for all remaining probe blanks.
- The o-ring should not be lubricated when being fitted please ensure it is completely dry.

4.5. PROBE CONNECTIONS

4.5.1. pH probe

On the end of the pH probe lead is a locking BNC plug. The BNC plug for the pH probe needs to fit into the back of the Davey Lifeguard controller, into the third BNC socket (refer Figure 4.16). The connector is deliberately designed such that it fits only one way.



Figure 4.16

4.5.2. ORP probe

On the end of the ORP probe lead is a locking BNC plug. The BNC plug for the ORP probe needs to fit into the back of the Lifeguard controller, into the second BNC socket (refer Figure 4.17). The connector is deliberately designed such that it fits only one way.



Figure 4.17

4.5.3. Temperature sensor and TDS probe

On the end of the temperature sensor and TDS probe lead is a locking BNC plug and an RCA plug. Both the BNC plug and the RCA plug needs to fit into the back of the Davey Lifeguard controller. The BNC plug for the TDS probe needs to fit into the first socket (refer Figure 4.18) and the RCA plug for the temperature sensor needs to plug into the RCA socket above it (refer Figure 4.19). The connector is deliberately designed such that it fits only one way.



Figure 4.18



Figure 4.19

On the back of the controller at the base, use the cable retention slots for all cables & leads, ref Figure 4.20.



Figure 4.20

4.6. THE DAVEY LIFEGUARD CONTROLLER

4.6.1. Powering the Davey Lifeguard controller



IMPORTANT: The Davey Lifeguard controller has been designed to constantly be powered on and in System On.

The product shall be connected to the installation protective earthing conductor (for example, by means of a power cord set connected to a socket-outlet with earthing connection). For pluggable equipment, the socket-outlet shall be easily accessible

On the back of the controller is an IEC input power socket.

- Connect the incoming power lead (supplied) into the IEC power socket on the rear of the Davey Lifeguard controller (refer Figure 4.21).
- The other end of the incoming power lead should be plugged into your 220-240VAC power supply.



Figure 4.21

4.6.2. Davey Lifeguard communication lead to Nipper

For the Davey Lifeguard controller to communicate to the Nipper, an RJ45 connection cable must be used. Plug the RJ45 connection cable into the back of the Davey Lifeguard controller (refer Figure 4.22). Plug the other end of the RJ45 connection cable into the back of Nipper (refer Figure 4.23).



Figure 4.22



Figure 4.23



ATTENTION: Power connections and wiring must only be carried out by suitably electrically qualified personnel. Both the Davey Lifeguard and Nipper must remain powered and communication lead firmly connected until the Nipper has been programmed. The Nipper will look like (refer Figure 4.24).



Figure 4.24

4.6.3. Connecting Lifeguard to PM400BT

For the Davey Lifeguard controller to communicate to the ProMaster PM400BT pool pump, an RJ45 connection cable must be used. Plug the RJ45 connection cable into the back of the Davey Lifeguard controller (refer Figure 4.25). Plug the other end of the RJ45 connection cable into the port of the Davey PM400BT (as explained in its I&OI – refer www.bit.ly/AUPMBTIOI).



Figure 4.25

	For adequate weatherproofing, the wall or post that Davey Lifeguard is mounted to, should be flat and at least as wide as the unit. Ensure the top and bottom of the Lifeguard is not protruding higher than what it is mounted to. Davey recommends installation under cover or eaves.
---	--

4.6.4. Mounting the Davey Lifeguard controller

The rear of the Davey Lifeguard controller has mounting supports 205mm apart (refer Figure 4.26).



Figure 4.26

The wall plug and screw kit provided should be used to mount the Davey Lifeguard controller. Davey recommends Davey Lifeguard mounting holes be drilled 170mm higher than the top of the current Nipper power supply box (refer Figure 4.27).

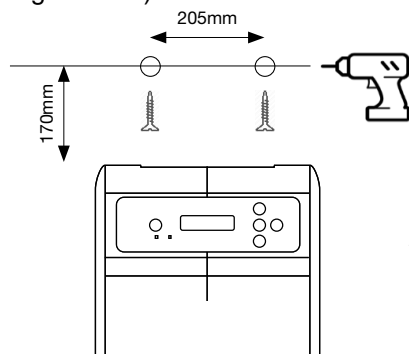

Figure 4.27

Before powering up the Davey Lifeguard ensure:

- All probes are plugged in to Lifeguard (as per section 4.5)
 - RJ45 communication cable and power lead connected
 - pH and salt water calibration solutions are nearby
 - The ORP probe has been in calibration solution for 10 minutes.
 - Pump is not powered and pipework pressure relieved
 - Power is connected and on to the Nipper Chlorinator
- Allow between 5 and 15 minutes for first time start-up

5. CONTROL PANEL

5.1 LAYOUT



Figure 5.1



System On/Off



Menu up/down



Menu/setting select



Menu/setting cancel (go back)



Power indicator
(lit when on)



Alarm indicator
(flashes when alarm active)

Time out
(whenever device is left for 30 seconds
without input from user, settings are saved,
and home **HOME SCREEN** displayed)

6. FIRST TIME START-UP PROCEDURE

Before attempting start up, ensure:

- all probes that you plan to use are plugged in and ready to be plumbed in;
- ORP probe has been in calibration solution for 10 minutes prior to calibration.
- have all your calibration solutions nearby;
- if a mistake is made, you can go back anytime using the Menu/setting cancel.



Allow between 4 and 15 minutes (depending on user confidence) for first time start-up.

6.1 LANGUAGE MENU

Upon initial power up, Davey Lifeguard runs through a start-up process. This process is also run if the system is put through a “factory reset”. The first screen displayed is the LANGUAGE menu (refer Figure 6.1).



Figure 6.1

- Scroll to your preferred language by using the  menu up/down buttons. Options include:
 - English;
 - French;
 - Dutch;
 - Portuguese;
 - Spanish;
 - German; and
 - Italian.
- Once your preferred language is highlighted, press  menu/setting select.

6.2 CLOCK FORMAT MENU

- The next screen shown is the **CLOCK FORMAT** menu (refer Figure 6.2);



Figure 6.2

- Scroll to your preferred clock format by using the **▲▼ menu up/down** buttons. Options include:
 - 12 hour clock; and
 - 24 hour clock.
- Once your preferred clock format is highlighted, press **● menu/setting select**.

6.3 CLOCK MENU

- The next screen shown is the **CLOCK** menu (refer Figure 6.3);



Figure 6.3

- Starting with the clock hours, use the **▲▼ menu up/down** buttons to adjust until correct, then press **● menu/setting select**.
- Repeat this process with clock minutes adjustment and AM/PM toggle (if 12 hour clock format has been chosen);
- The display will then request clock confirmation (refer Figure 6.4);



Figure 6.4

- Press **● menu/setting select** to save and continue.

6.4 POOL VOLUME MENU

- The next screen shown is the **POOL VOLUME** menu (refer Figure 6.5);

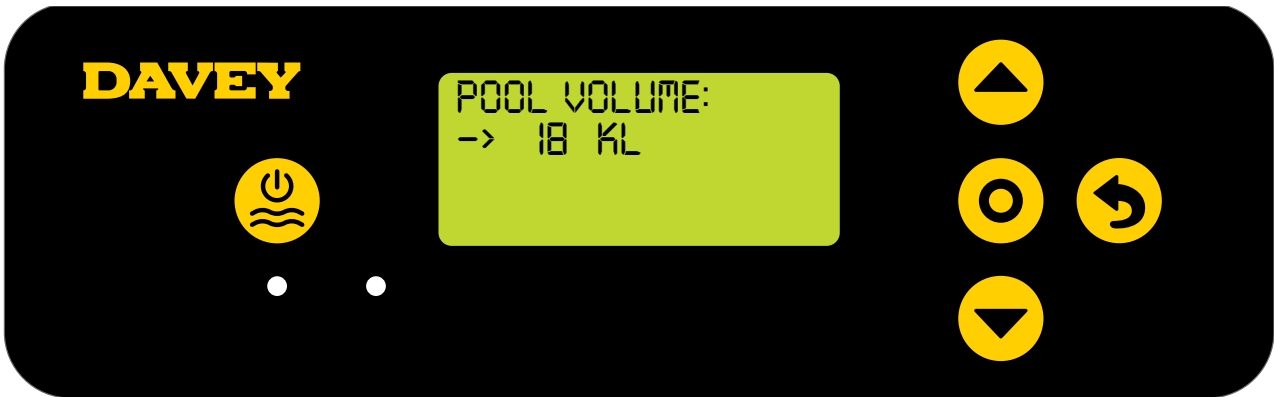



Figure 6.5

- Use the  menu up/down buttons to adjust the **POOL VOLUME** menu until correct, then press  menu/setting select.

6.5 PH PROBE MENU

- The next screen shown asks if the pH probe is currently connected and to be used (refer Figure 6.6);

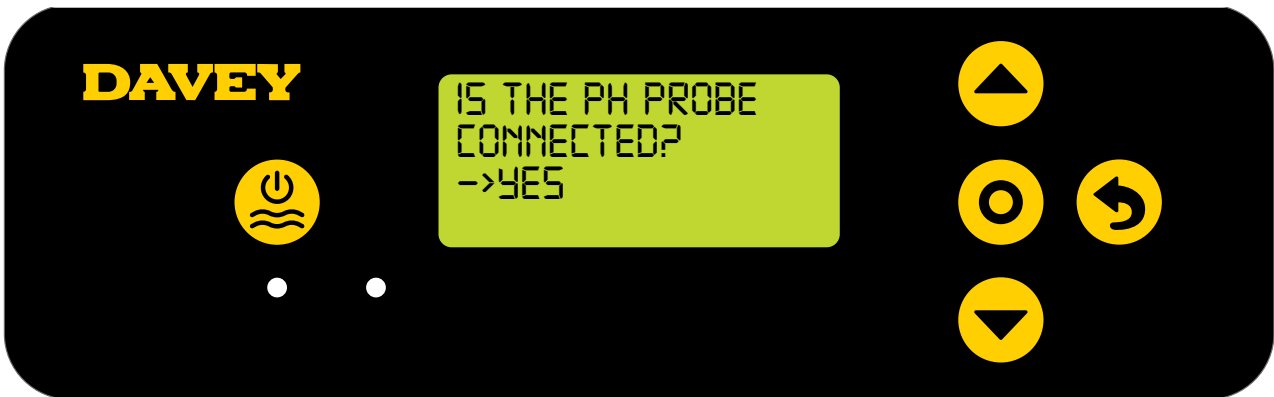



Figure 6.6

- Use the  menu up/down buttons to toggle between yes and no;
- Once correct, then press  menu/setting select;
- If you've chosen not to use the pH probe, skip to step 6.5 of this manual;
- If you've chosen to use the pH probe, the next screen will instruct you to put the pH probe into pH 7 solution (ref Figure 6.7);

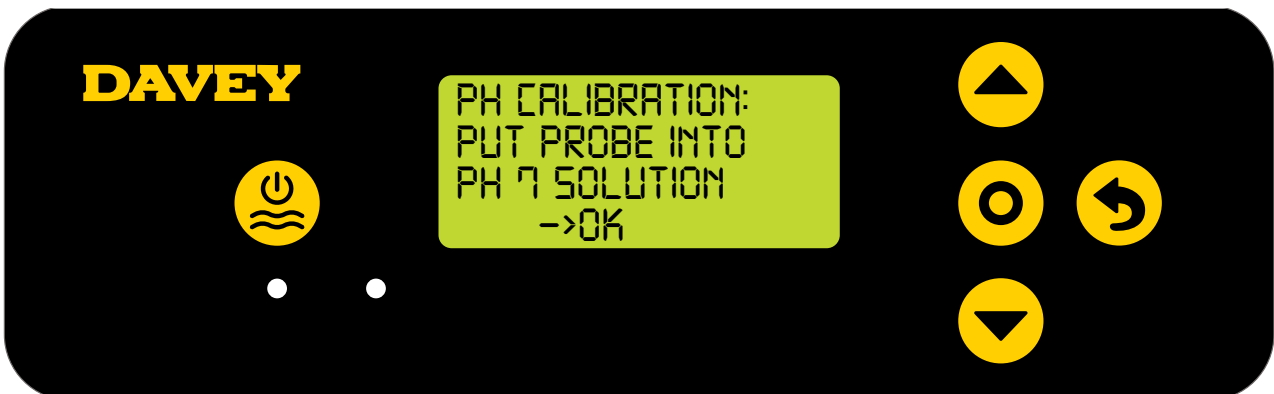

Figure 6.7



ATTENTION: When packaged, the probe comes connected to a bottle of chemical solution (refer to technical specifications section for MSDS availability). Do not drink the solution. The excess solution should be kept for future winterising of probes.

- Carefully unscrew the bottom half of the bottle, from the bottle's lid (refer Figure 6.8). Do not attempt to pull the whole bottle off the probe as you risk damaging the probe end;



Figure 6.8

Figure 6.9

- Now carefully slide the lid and o-ring off the end of the probe. Ensure the probe end remains intact and ideally untouched (refer Figure 6.9). If the probe end is broken, the probe will need to be replaced (refer to spare parts section at the back of this manual). If the probe is touched, simply use a soft cloth, or tissue to clean, then resoak the probe in its chemical solution for 60 seconds;



Figure 6.10

- At this point, ensure that the pH probe is placed into the pH 7 solution (ref Figure 6.10). Currently the probe blanking plug should be plumbed into the probe & injection point housing, you will need to remove it. Ensure that your circulation pump isn't running, or isn't about to run. For above ground pools (or pools where the water level is higher than the equipment) it may be necessary to close isolation valves to ensure water doesn't flood from the pool;



Figure 6.11

- Once the pH probe is bathing in pH 7 solution, press  **menu/setting select**;
- The screen will next display pH calibration in progress (refer Figure 6.12). A count will commence. Typically, the calibration will take less than 15 seconds, but may take up to a minute;



Figure 6.12

- Once complete, the display will instruct you to remove the probe (refer Figure 6.13).



Figure 6.13

- The probe can then be removed from the pH calibration solution and installed into the probe and injection housing. The injection housing has written in the moulding which probe is mounted where (refer Figure 6.14);

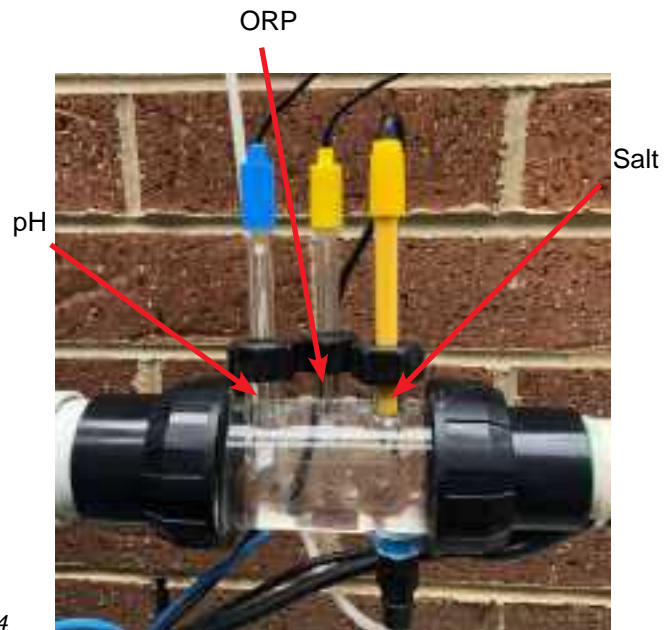

Figure 6.14

- On the probe and injection housing, under each of the 3 x probe locking nuts, is an o-ring and washer (refer Figure 6.15). Remove the first probe locking nut on the housing (where it's marked pH);

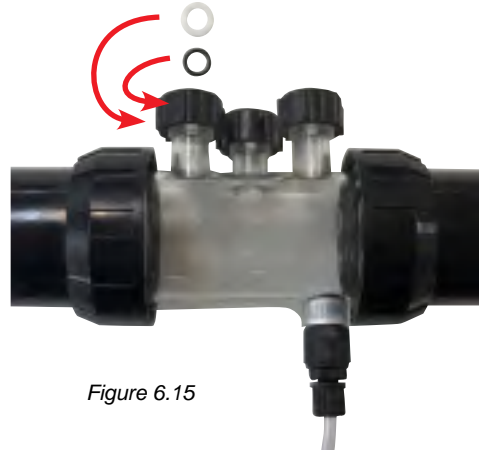

Figure 6.15

- Carefully slide the probe locking nut, then the washer, then the o-ring, onto the probe (refer Figure 6.16);
- The o-ring should not be lubricated when being fitted, please ensure it is completely dry.

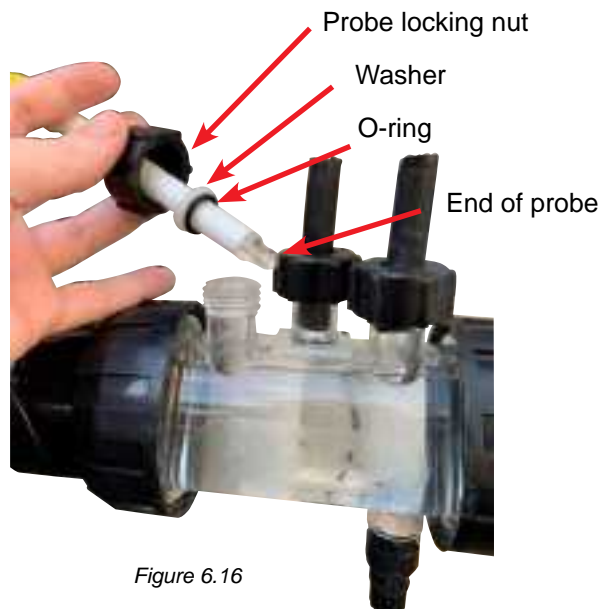

Figure 6.16

- When sliding the probe into the probe housing, ensure that the probe is located more than ½ way into the probe housing (refer Figure 6.17).



Probe not in far enough



Probe in too far



Figure 6.17

- Hand tighten the probe locking nut onto the probe housing, that will in turn tighten the washer onto the o-ring (and create a seal).
- It is a good idea to periodically check the nuts securing the probes onto the manifold to ensure they haven't come loose.



IMPORTANT: Ensure that the probe isn't inserted too far into the probe housing. Pushing the probe against the inside of the probe housing (on the underside) risks breaking the glass. Do not over tighten the probe locking nut onto the probe housing.

- Press  **menu/setting select**, the display then shows the pH set point (refer Figure 6.18);

The factory default pH set point is 7.4, however you may wish to change this once the Davey Lifeguard is installed. It should be noted that Chlorine's effectivity is greatly influenced if pH levels are too high, or too low. Davey recommends the pool chemistry levels shown in section 10.



Figure 6.18

Adjustments to pH set point can be made as follows:

- Use the  **menu up/down** buttons to scroll to your desired set point;
- Once correct, then press  **menu/setting select**.

6.6 ORP PROBE MENU

- The next screen shown asks if the ORP probe is currently connected and to be used (refer Figure 6.19). Unlike the pH probe, the ORP probe needs to be left to soak in its calibration solution for 10 minutes prior to calibrating. You may wish to elect to come back this step later, or if you've chosen not to use the ORP probe, skip to step 6.7 of this manual. The ORP probe can always be re-calibrated after initial installation, refer Section 8.2.2;

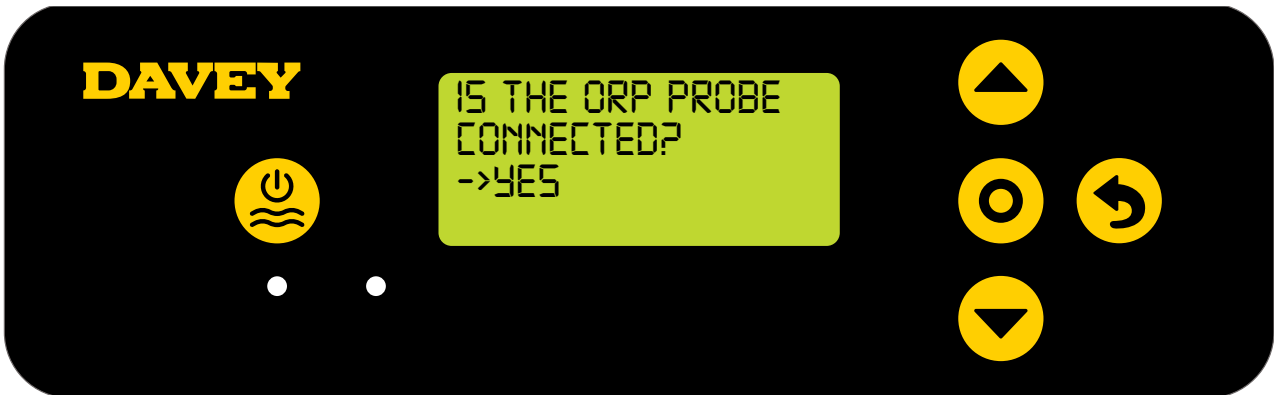

Figure 6.19



- Use the   **menu up/down** buttons to toggle between yes and no. Once correct, then press  **menu/setting select**;
- If you've chosen not to use the ORP probe, skip to step 6.7 of this manual;
- If you've chosen to use the ORP probe, the next screen will instruct you to put the ORP probe into the ORP solution (ref Figure 6.20);



Figure 6.20

- With the ORP probe in its solution, press  **menu/setting select**;
- The screen will next display ORP calibration in progress (refer Figure 6.21). A count will commence. Typically, the calibration will take less than 15 seconds, but may take up to a minute;



Figure 6.21

- Once complete, the display will instruct you to remove the probe (refer Figure 6.22).



Figure 6.22

- The probe can then be removed from the calibration solution and re-installed back into the probe & injection housing.
- On the probe and injection housing, under each of the 3 x probe locking nuts, is an o-ring and washer (refer Figure 6.23). Remove the second probe locking nut on the housing (where it's marked ORP);

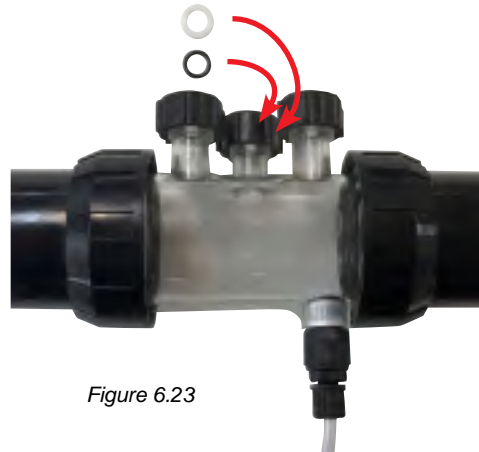

Figure 6.23

- Press **○ menu/setting select**, the display then shows the ORP set point (refer Figure 6.24). The factory default ORP set point is 650mV, however you may wish to change this once the Davey Lifeguard is installed.



Figure 6.24

It should be noted that Chlorine's effectivity is directly related to the pool water's ORP level as explained in section 3. Davey recommends following the pool levels shown in section 10. Adjustment to the ORP set point can be made as follows:

- Use the ▲▼ menu up/down buttons to scroll to your desired set point. Once correct, then press ● menu/setting select.

Should you select NO for "Is the ORP probe connected?" you will be shown a screen to choose a Chlorine Output. This step is only necessary if you select NO ORP probe. Should you wish to control the Chlorine output manually, Lifeguard's Chlorine output works the same as explained in the Nipper manual. Refer to the relevant section following URL www.bit.ly/nippercm

6.7 SALT PROBE MENU

- The next screen shown asks if the salt/conductivity probe is currently connected and to be used (refer Figure 6.25);

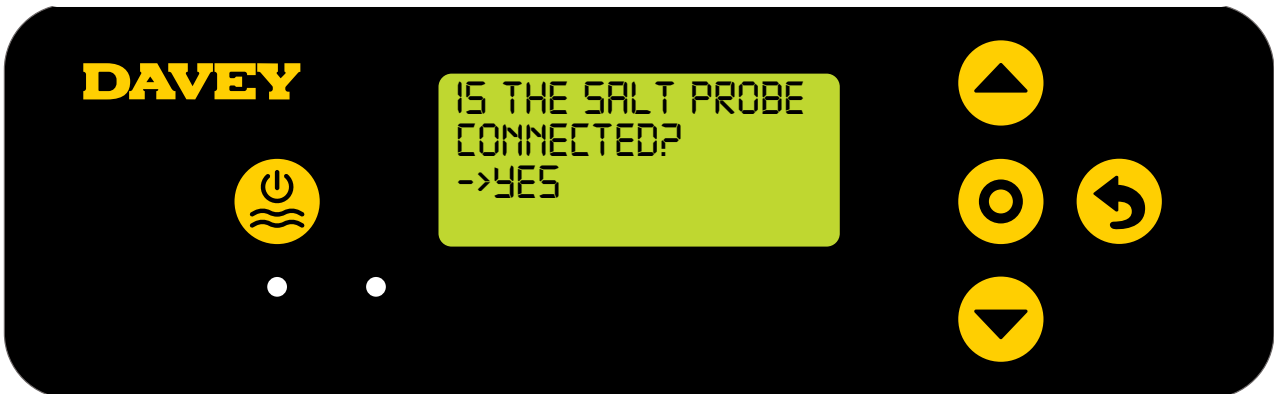

Figure 6.25

- Use the ▲▼ menu up/down buttons to toggle between yes and no. Once correct, then press ● menu/setting select.
- If you've chosen not to use the salt probe, skip to section 7 of this manual;
- If you've chosen to use the salt probe, the next screen will display 0ppm salt (refer Figure 6.26).

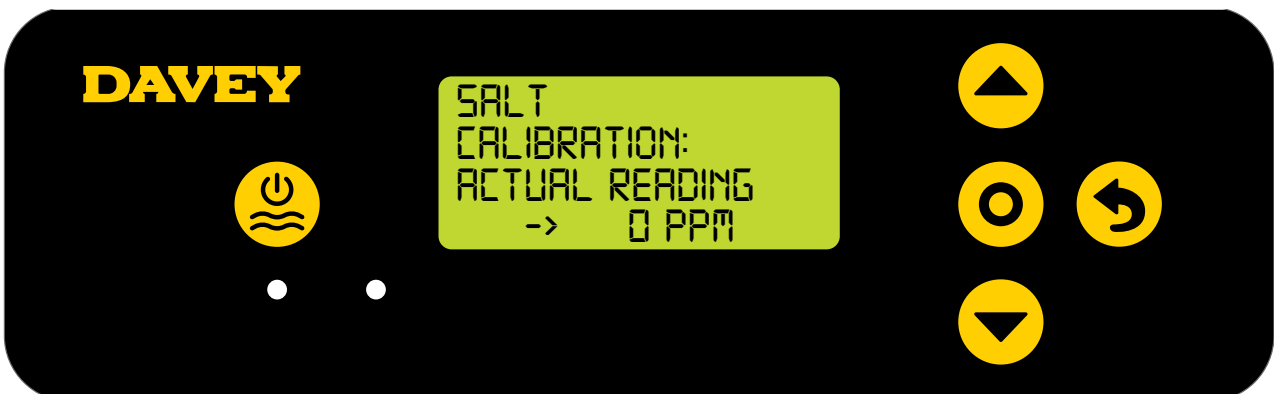

Figure 6.26

- Carefully unscrew the bottom half of the bottle, from the bottle's lid. Do not attempt to pull the whole bottle off the probe as you risk damaging the glass probe end;
- Place the salt probe into the TDS solution, press the ▲▼ menu up/down buttons to scroll to show 3000ppm, then press Ⓞ menu/setting select;

6.8 TEMP PROBE MENU

- The next screen asks if the temperature probe is currently connected and to be used (refer Figure 6.27). The temperature probe is the same probe as the salt probe, but it does plug into the Davey Lifeguard controller by a separate socket;

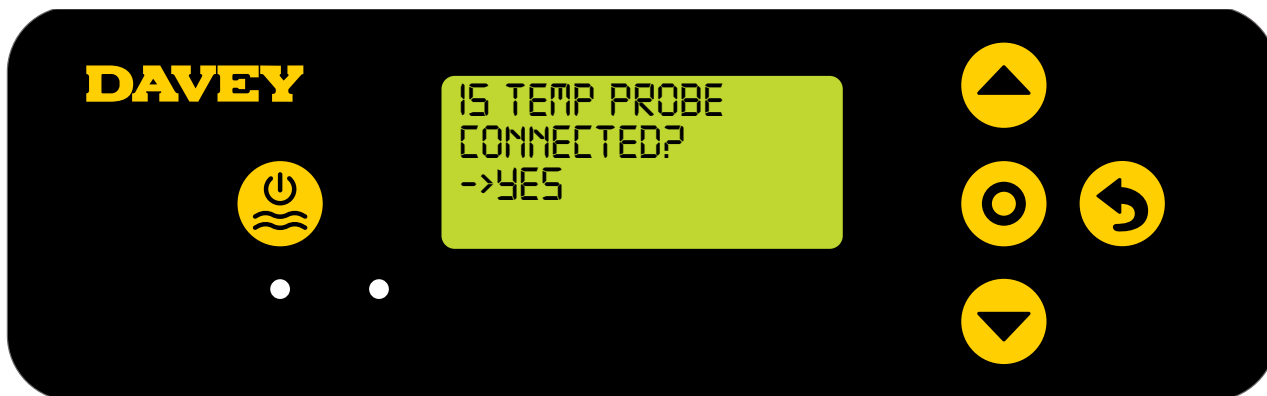

Figure 6.27

- Use the ▲▼ menu up/down buttons to toggle between yes and no.
- Once correct, then press Ⓞ menu/setting select;
- If you've chosen to use the temperature probe, use the ▲▼ menu up/down buttons to display the current temperature of the pool's water.

7. CONNECTING DAVEY LIFEGUARD TO WiFi

Connecting your Davey Lifeguard to WiFi means you can monitor and control your pool remotely via the app and staying connected will mean you have access to the latest software updates for the device.

NOTE: Your Wi-Fi username/SSID and password must be less than 18 characters.

Before you connect to WiFi ensure you have a strong WiFi connection at the pool equipment area where the Davey Lifeguard is installed. At minimum (and most reliable for Lifeguard) the Download speed should be at least 12Mbps for Lifeguard. Use <https://www.speedtest.net/> to test the WiFi network download/upload speed. You may need to extend your WiFi signal by purchasing a WiFi repeater. Make sure your WiFi is 2.4 GHz. In Australia and NZ, Davey recommends the use of following Wifi Extenders:

* The TP-LINK RE450; or * The Netgear EX6250.

Should you wish to connect your Davey Lifeguard to WiFi, follow these steps, otherwise skip to the next section. You can connect to WiFi at anytime.

- From the app store (or Apple Store), download the DAVEY LIFEGUARD app.

NOTE: You will need to allow all location data either on app startup or in app settings.

- Open App on smart device
- Create an account
- Go to your Davey Lifeguard module, turn on Bluetooth in the settings menu by entering the password 1234
- With your smart device connected to Wi-Fi, connect your Davey Lifeguard to the internet



Davey *Figure 7.1*

- You can also watch the demo video on the first screen.

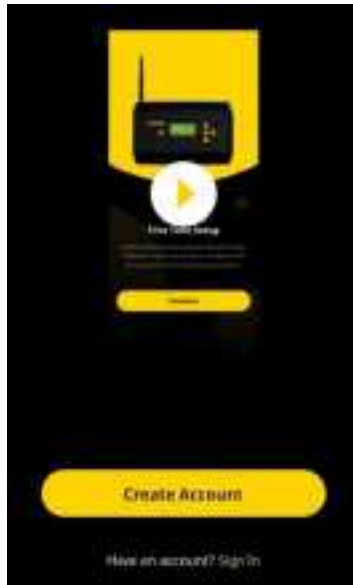

Figure 7.2

- Alternately, the demo video can be viewed from: https://www.daveywater.com/resources/pool/LG_App_1stTimeSetup.mp4 The demo video walks through the initial setup of connecting the Davey Lifeguard controller to the internet.



This symbol confirms Davey Lifeguard’s connection to Nipper. If the “N” is flashing, Lifeguard is attempting to connect. If the “N” is solid, the connection is made;



This symbol confirms Davey Lifeguard’s connection to the internet. If the symbol is shown solid, it indicates that Davey Lifeguard is connected to the internet. If it is flashing, Davey Lifeguard isn’t connected to the internet; and



This symbol shows the signal strength of the local wifi.

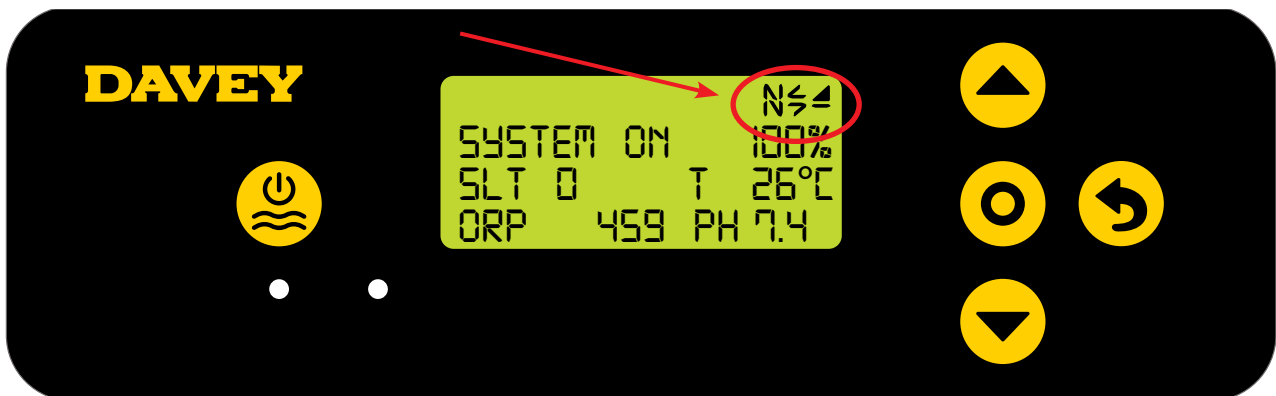



Figure 7.3

7.1 FIRMWARE UPDATES

As is the case with most “smart devices”, it is important to ensure that your Davey Lifeguard and Davey Nipper has the latest revision of firmware. When a critical firmware update is released, your Davey Lifeguard &/or Davey Nipper will be able to update over the air (OTA), as long as they are correctly connected to the internet. Davey recommends forcing an OTA firmware update of both the Lifeguard and Nipper systems on installation and periodically after installation to ensure you are using the latest firmware release. It is important to start with the Lifeguard:

- On the Lifeguard controller, hold down the  menu down button for approx 5 seconds.
- The display will go blank.
- Then the words “software update in progress” will appear on the display.

- To update your Chloromatic Nipper, hold down the  menu/setting cancel (go back) button on your Lifeguard controller for approx 5 seconds..
- The display will again go blank & the software update will occur.

Firmware versions can be checked on the Davey Nipper by turning the unit off at the power and turning back on, the screen will display the current version.

On the Lifeguard unit, the firmware version can be found in the 'about' section in settings or in the 'device information' section in the app settings.

7.2 WiFi CONNECTION

If your WiFi signal drops out or stops working, your Davey Lifeguard will automatically reconnect when the signal is restored.

There is no need to attempt a manual reconnection.

If you experience dropouts of the Lifeguard connection while the WiFi is working correctly you may need to install a WiFi extender to maintain a strong signal at the unit. Refer to section 7.0 for recommendations on WiFi extenders.

WiFi signal strength can be effected by:

- Network traffic
- Physical obstructions
- Other wireless networks and devices
- Distance from the modem/router

8. OPERATIONAL INSTRUCTIONS

8.1 PH CONTROL

In a swimming pool application, control of the water's pH is essential in order to allow Chlorine to correctly and efficiently oxidise pathogens in the water. The Davey Lifeguard's **HOME SCREEN** (refer Figure 8.1) shows the current pH of the pool water, as measured from the Davey Lifeguard's pH probe.

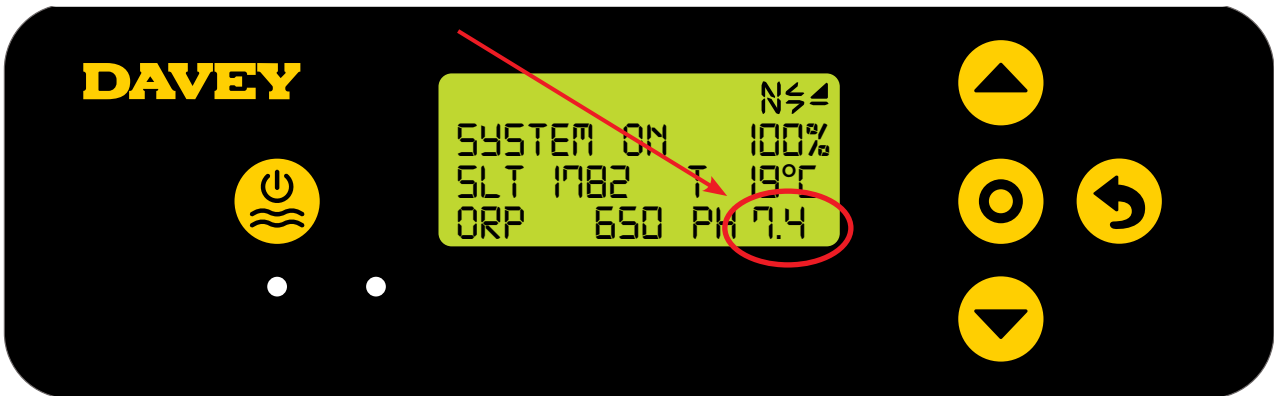

Figure 8.1

This can also be observed from the dashboard of the Davey Lifeguard app (refer Figure 8.2).

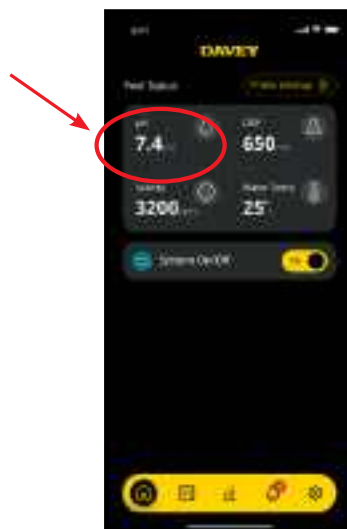

Figure 8.2

8.1.1. Adjusting pH set point

The factory default pH set point is 7.4, however you may wish to change this once the Davey Lifeguard is installed. It should be noted that Chlorine's effectivity is greatly influenced if pH levels are too high, or too low. Davey recommends following the pool chemistry levels shown in section 10. Adjustments to pH set point can be made as follows.

8.1.1.1. On the Davey Lifeguard control panel

- From the **HOME SCREEN**, press the  **menu/setting select** button. This will now show the main menu (Figure 8.3);



Figure 8.3

- Press the  **menu up/down** button to scroll down to settings (Figure 8.4);



Figure 8.4

- Press the  **menu/setting select** button. This will now show the settings menu (Figure 8.5);



Figure 8.5

- Press the  **menu/setting select** button. The next screen ask "is the pH probe connected?" (Refer Figure 8.6);

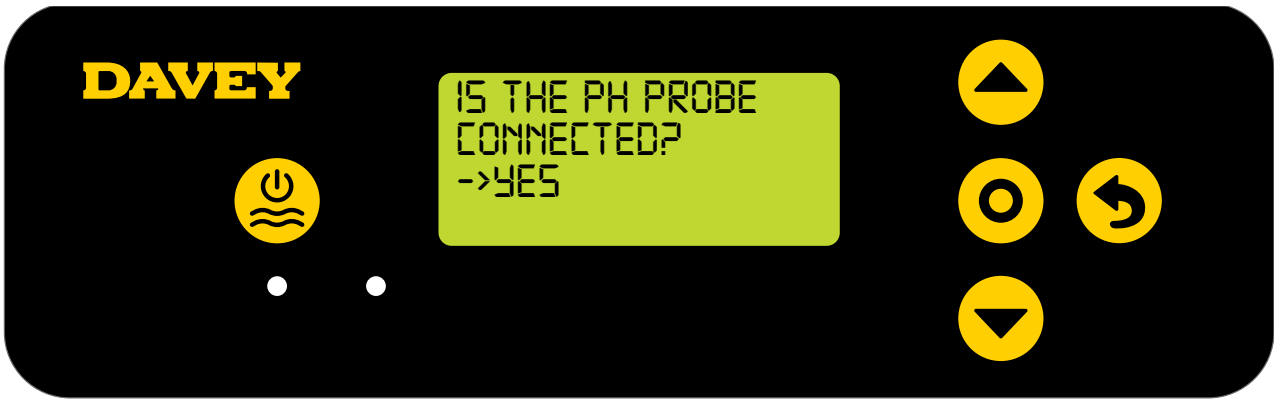

Figure 8.6

- Press the **menu/setting select** button. The next screen shows the current pH set point (Refer Figure 8.7);



Figure 8.7

- Should you wish to change the setting, use the **menu up/down** buttons to scroll the display to your desired pH set point. Once your desired pH set point is displayed, press the **menu/setting select** button. The change is then saved, and the display reverts back to the settings menu.
- Press the **menu/setting cancel (go back)** button twice to revert back to the **HOME SCREEN**.

8.1.1.2. Using the app

- From the dashboard of the Davey Lifeguard app, press “probe settings” (refer figure 8.8);

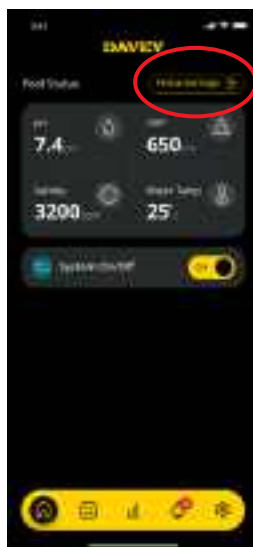

Figure 8.8

- In the probe setting menu, you’ll notice that the current pH set point. From the probe settings menu, press “edit” (ref figure 8.9);



Figure 8.9

- From the pH adjustment menu, scroll the dial onscreen to edit the pH set point (refer figure 8.10);



Figure 8.10

- Once your preferred set point is shown, press “save” (refer figure 8.11);

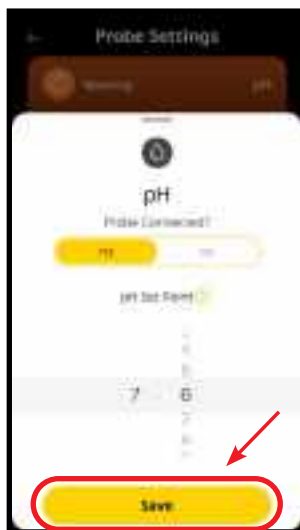

Figure 8.11

- Once you're back to the probe setting menu, you'll notice that the pH set point has changed (refer figure 8.12);



Figure 8.12

- Now simply press the back arrow button at the top left corner to return to the dashboard of the Davey Lifeguard app (refer figure 8.13).



Figure 8.13

8.1.2. RE-CALIBRATING pH PROBE

Checking the calibration of the probe is a good practice to do on a 3-monthly basis. Conduct a water analysis with a reliable pool water test kit and compare the reading from the test kit, to the reading from the Davey Lifeguard probe. Realistically, there'll be very little adjustment required initially. However, the probes are sacrificial and will deteriorate with age. The older the probes become, the more likely the need for re-calibration, until the point of replacement. If the probe is damaged, it will require replacement (refer to spare parts listing at the back of this manual). Upon replacement of the probe, a new re-calibration should be performed.

8.1.2.1. On the Davey Lifeguard control panel

- From the **HOME SCREEN**, press the **ⓘ** menu/setting select. This will now show the main menu (Figure 8.14);



Figure 8.14

- Press the ▲▼ menu up/down button to scroll down to maintenance (Figure 8.15);



Figure 8.15

- Press the ▲▼ menu up/down button (Figure 8.16);

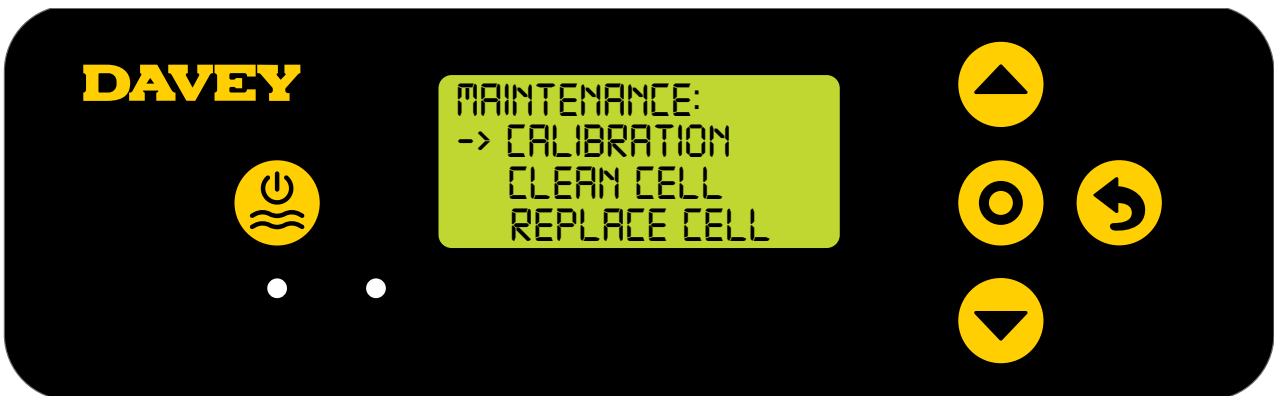

Figure 8.16

- Press the ▲▼ menu up/down buttons to scroll down to PH CAL (Figure 8.17). Then press the ● menu/setting select button;

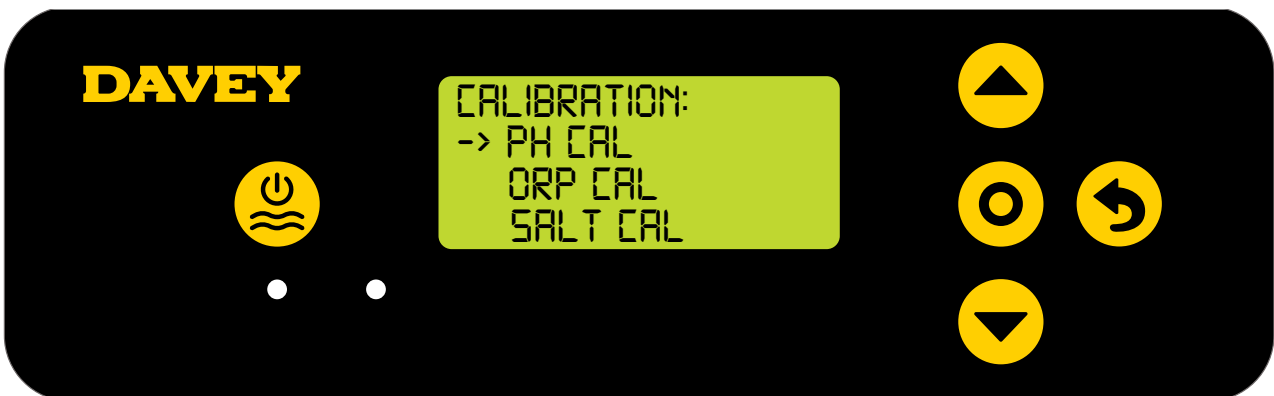

Figure 8.17

- Now follow the instructions for PH calibration from section 6.6.

8.1.2.2. Using the app

Note: the pH cannot be calibrated via the app.

8.1.3. Overriding/ignoring pH probe

Should the need arise whereby the pH probe needs to be isolated (turned off, or ignored) this is possible both via the Lifeguard control panel, or via the Davey Lifeguard app. This may become necessary if the probe is damaged during a maintenance clean. If the probe is damaged, refer to maintenance section 11.

Note: If you turn off your pH probe, your acid pump will not turn on and will not maintain your pH levels.

8.1.3.1. On the Lifeguard control panel

- From the **HOME SCREEN**, press the ● menu/setting select button. This will now show the main menu (Figure 8.18);

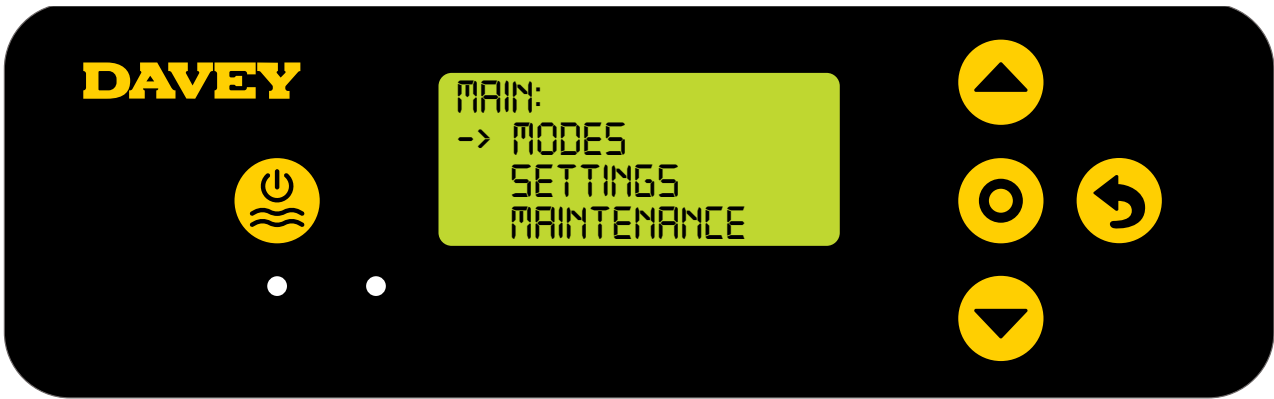

Figure 8.18

- Press the  menu up/down, scrolling down to settings (Figure 8.19);



Figure 8.19



- Press the  menu/setting select button. This will now show the settings menu (Figure 8.20);



Figure 8.20

- Press the  menu/setting select button. The next screen will ask “is the pH probe connected?” (Refer Figure 8.21);

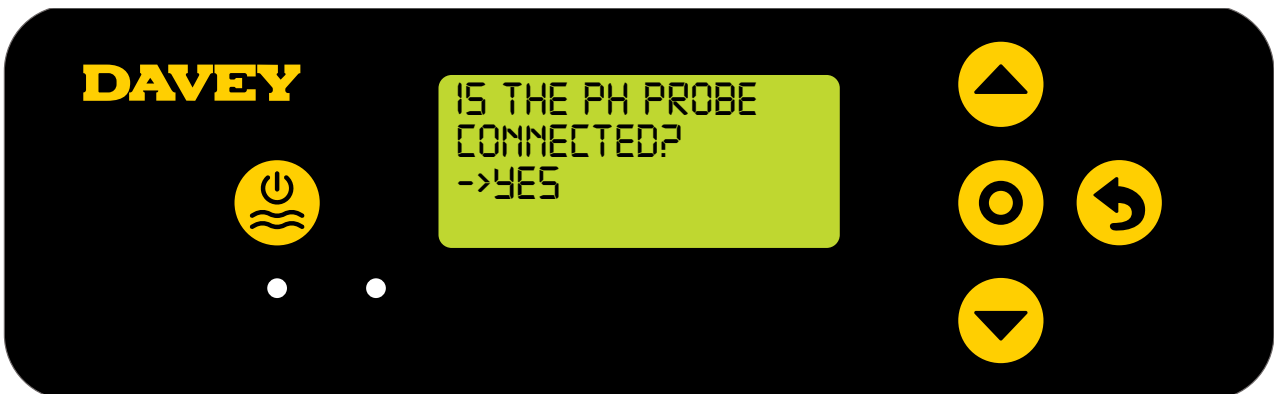

Figure 8.21

- Should you wish to change the setting, use the  menu up/down to scroll the display to “NO” (refer Figure 8.22);

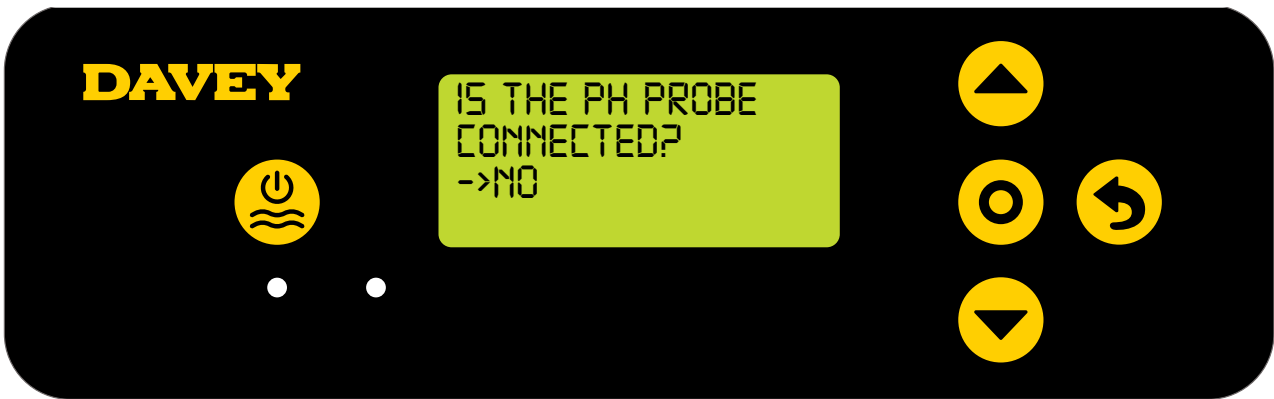



Figure 8.22

- Then press the  menu/setting select button. The change is then saved, and the display reverts back to the settings menu.

8.1.3.2. Using the app

- From the dashboard of the Davey Lifeguard app, press “probe settings” (refer figure 8.23);

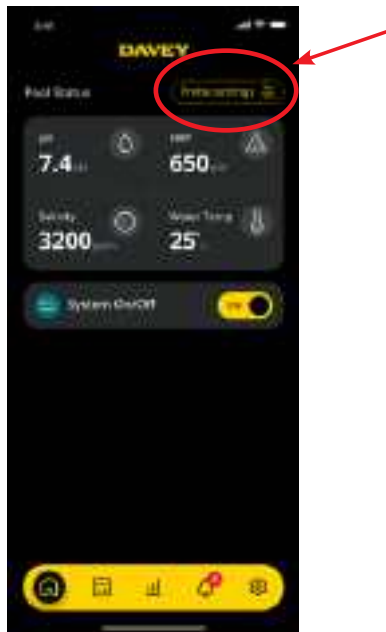

Figure 8.23

- In the probe setting menu, press “edit” (ref figure 8.24);



Figure 8.24

- From the pH adjustment menu, under “Probe connected”, press no, then press “save” (refer figure 8.25);

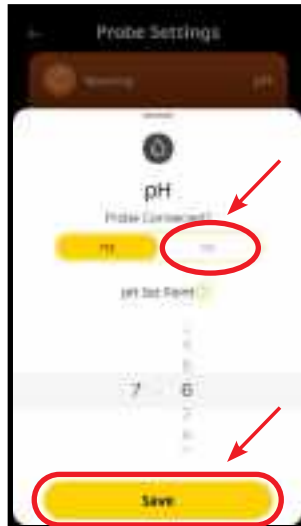

Figure 8.25

- Once you're back in the probe setting menu, where the pH reading was previously shown, it will now read “no probe” (refer figure 8.26).

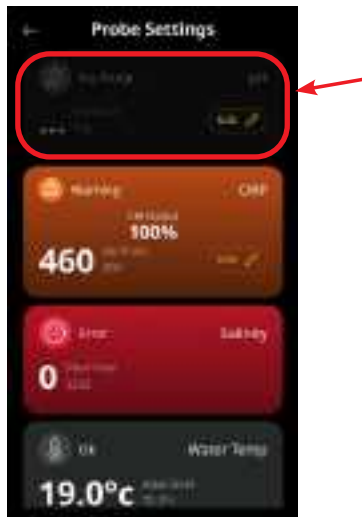

Figure 8.26

- Press the back arrow to return to the dashboard of the Davey Lifeguard app (refer figure 8.27).



Figure 8.27

8.2 ORP/CHLORINE CONTROL

In a swimming pool application, control of the water's Chlorine level is essential in order to correctly and efficiently oxidise pathogens in the water. The Davey Lifeguard's **HOME SCREEN** (refer Figure 8.28) shows the current ORP of the pool water, as measured from the Davey Lifeguard's ORP probe.

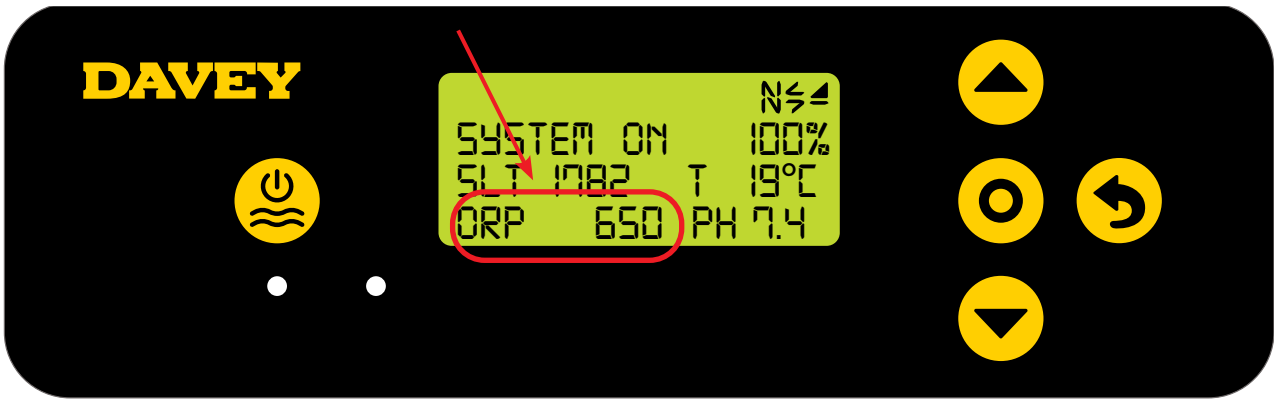

Figure 8.28

This can also be observed from the dashboard of the Davey Lifeguard app (refer Figure 8.29).



Figure 8.29

8.2.1. Adjusting ORP set point

The factory default ORP set point is 650mV, however you may wish to change this once the Lifeguard is installed. It should be noted that Chlorine's effectivity is greatly influenced if pH levels are too high, or too low. Davey recommends following the pool levels shown in section 10. Adjustments to ORP set point can be made as follows.

8.2.1.1. On the Davey Lifeguard control panel

- From the **HOME SCREEN**, press the  **menu/setting select** button. This will now show the main menu (Figure 8.30);



Figure 8.30

- Press the  menu up/down button to scroll down to settings (Figure 8.31);



Figure 8.31

- Press the  menu/setting select button. This will now show the settings menu (Figure 8.32);



Figure 8.32



- Press the  menu up/down button to scroll down to ORP set point (Figure 8.33);



Figure 8.33

- Press the  menu/setting select button. The next screen will ask "is the ORP probe connected?" (Refer Figure 8.34);

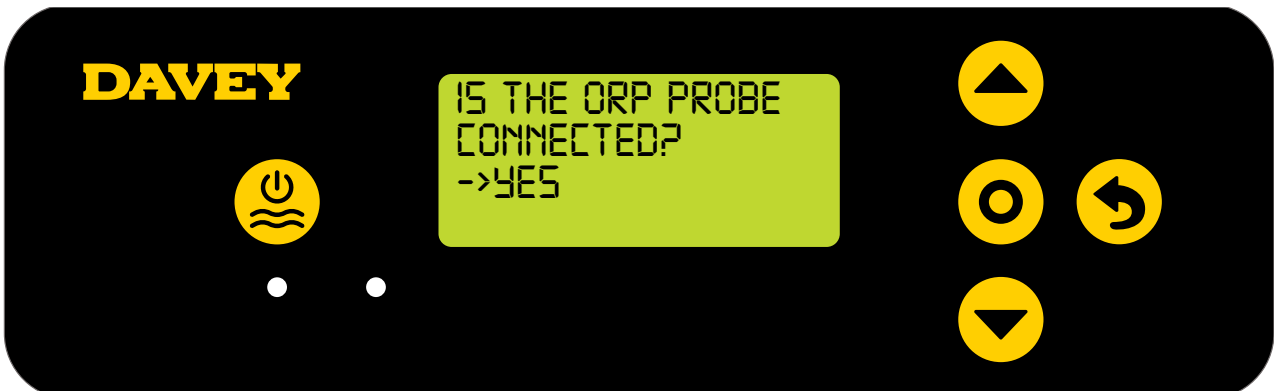

Figure 8.34





- Press the  **menu/setting select** button. The next screen shows the current ORP set point (Refer Figure 8.35);



Figure 8.35

- Should you wish to change the setting, use the   **menu up/down** buttons to scroll the display to your desired ORP set point. Once your desired ORP set point is displayed, press the  **menu/setting select** button. The change is then saved, and the display reverts back to the settings menu.
- Press the  **menu/setting cancel (go back)** button twice to revert back to the **HOME SCREEN**.

8.2.1.2. Using the app

- From the dashboard of the Davey Lifeguard app, press “probe settings” (refer figure 8.36);

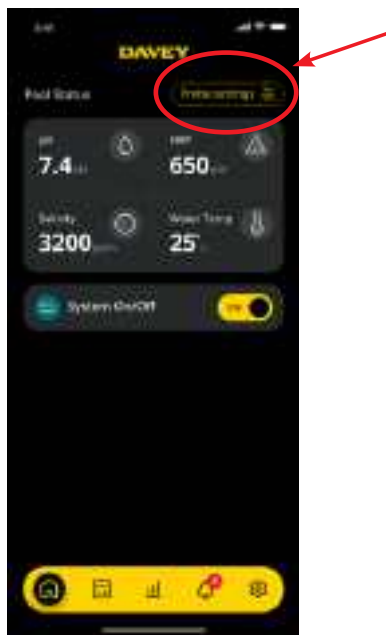

Figure 8.36

- In the probe setting menu, press “edit” (ref figure 8.37);



Figure 8.37

- From the ORP adjustment menu, scroll the dial onscreen to edit the ORP set point (refer figure 8.38);

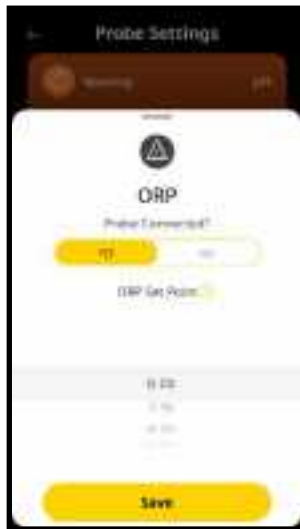

Figure 8.38

- Once your preferred set point is shown, press “save” (refer figure 8.39);

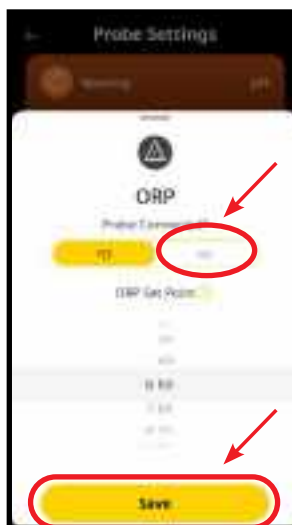

Figure 8.39

- Once you're back to the probe setting menu, you'll notice that the ORP set point has changed (ref figure 8.40);



Figure 8.40

- Press the back arrow to return to the dashboard of the Davey Lifeguard app (refer figure 8.41).



Figure 8.41

8.2.2. Re-calibrating ORP probe

Checking the calibration of the probe is a good practice to do on a 3-monthly basis. Conduct a water analysis with a reliable pool water test kit and compare the reading from the test kit, to the reading from the Davey Lifeguard probe. Realistically, there'll be very little adjustment required initially. However, the probes are sacrificial and will deteriorate with age. The older the probes become, the more likely the need for re-calibration, until the point of replacement. Upon replacement of the probe, a new re-calibration should be performed.

8.2.2.1. On the Davey Lifeguard control panel

- From the **HOME SCREEN**, press the  **menu/setting select** button. This will now show the main menu (Figure 8.42);



Figure 8.42

- Press the ▲▼ menu up/down button to scroll down to maintenance (Figure 8.43);



Figure 8.43

- Press the ▲▼ menu up/down button (Figure 8.44);

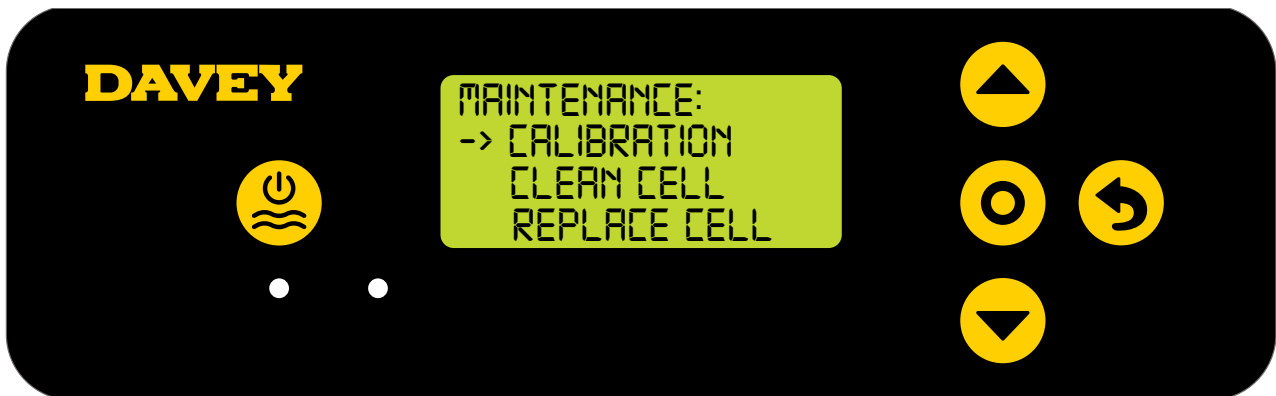

Figure 8.44

- Press the ▲▼ menu up/down buttons to scroll down to ORP CAL (Figure 8.45). Then press the ● menu/setting select button;

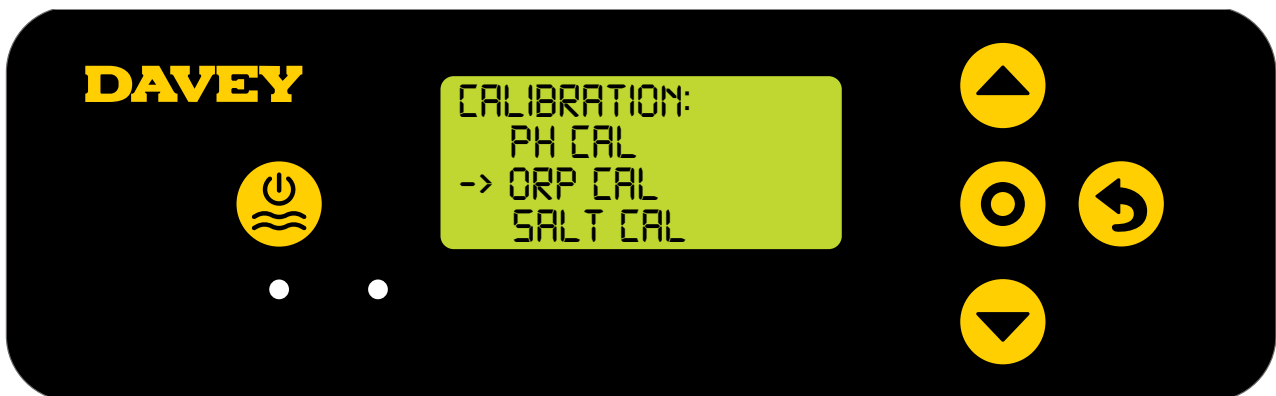

Figure 8.45

- Now follow the instructions for ORP calibration from section 6.6.

8.2.2.2. Using the app

Note: the ORP probe cannot be calibrated via the app.

8.2.3. Overriding/ignoring ORP probe

Should the need arise whereby the ORP probe needs to be isolated (turned off, or ignored) this is possible both via the Davey Lifeguard control panel, or via the Davey Lifeguard app. This may become necessary if the probe is damaged during a maintenance clean. If the probe is damaged, refer to maintenance section 11.

Note: If you turn off your ORP probe, you will be prompted to enter a % output for the chlorinator to maintain chlorine levels in your pool without the ORP measurement. Please refer to Davey Chlormatic Nipper installation and operating instructions for guidance on setting the output.

8.2.3.1. On the Davey Lifeguard control panel

- From the **HOME SCREEN**, press the  **menu/setting select** button. This will now show the main menu (Figure 8.46);



Figure 8.46

- Press the  **menu up/down** to scroll down to settings (Figure 8.47);



Figure 8.47



- Press the  **menu up/down** button to scroll down to ORP set point (Figure 8.48);



Figure 8.48

- Press the  **menu/setting select** button. The next screen will ask "is the ORP probe connected?" (Refer Figure 8.49);

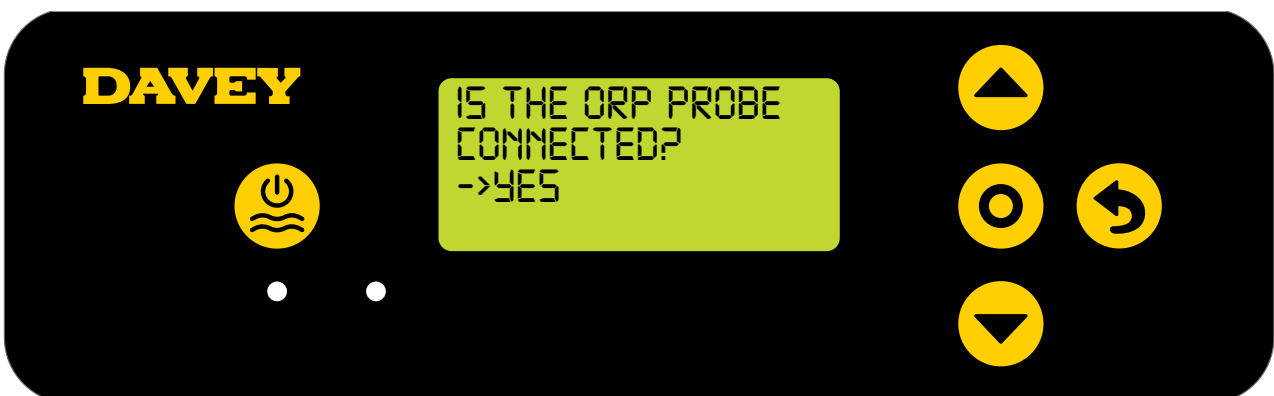

Figure 8.49

- Should you wish to change the setting, use the ▲▼ menu up/down to scroll the display to “NO” (refer Figure 8.50);

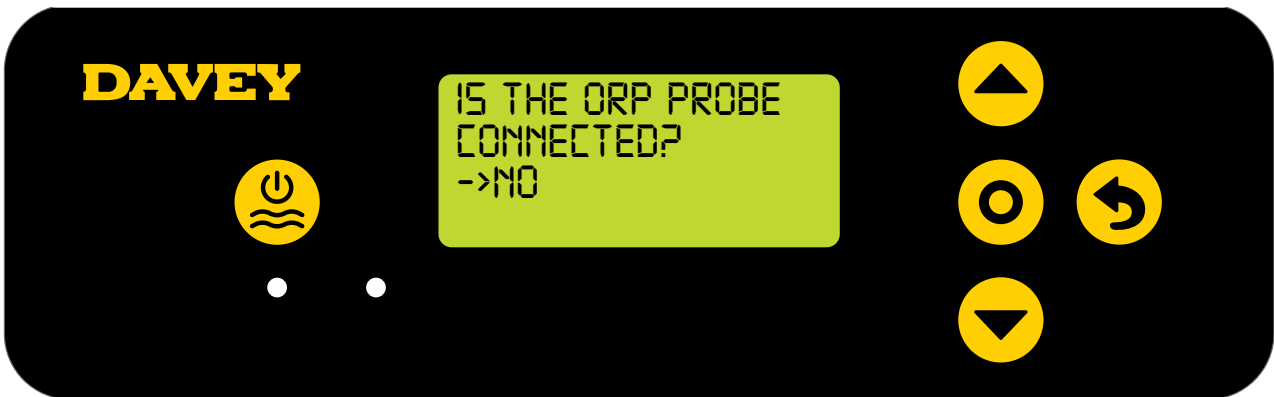

Figure 8.50

- Press the ▲▼ menu up/down buttons to scroll to your chosen CHLORINE OUTPUT (Figure 8.51);
- This step is only necessary if you select NO ORP probe. Should you wish to control the Chlorine output manually, Lifeguard’s Chlorine output works the same as explained in the Nipper manual. Refer to the relevant section following URL www.bit.ly/nippercm

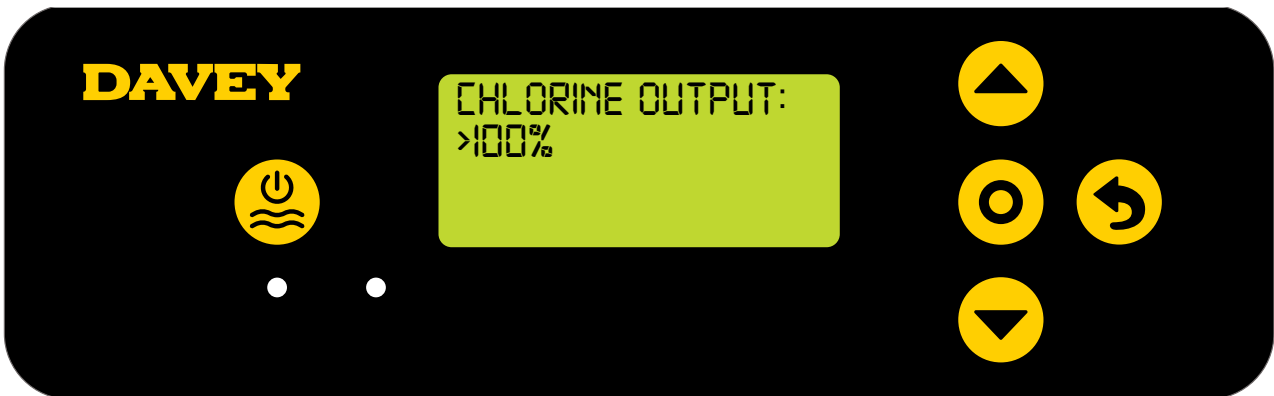

Figure 8.51

- Then press the ● menu/setting select button. The change is then saved, and the display reverts back to the settings menu.

8.2.3.2. Using the app

- From the dashboard of the Davey Lifeguard app, press “probe settings” (refer figure 8.52);



Figure 8.52

- In the probe setting menu, press “edit” (ref figure 8.53);

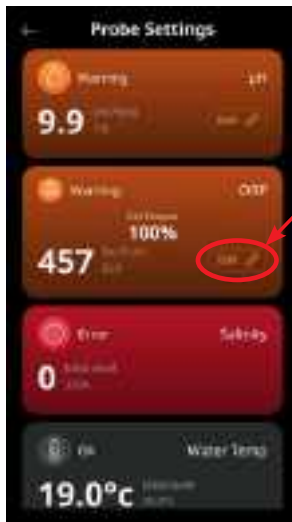

Figure 8.53

- From the ORP adjustment menu, under “Probe connected”, press no, then press “save” (refer figure 8.54);

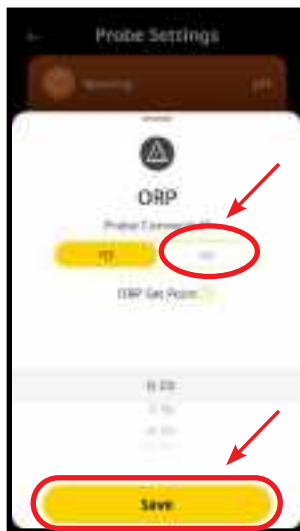

Figure 8.54

- Once you’re back in the probe setting menu, where the ORP reading was previously shown, it will now read “no probe” (refer figure 8.55).

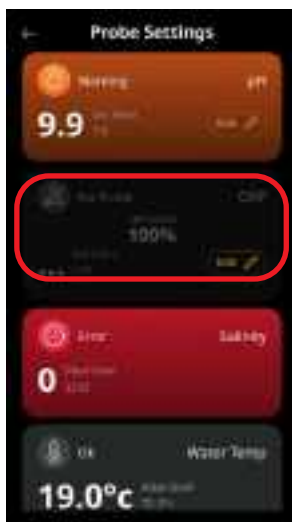

Figure 8.55

- Now simply press the back arrow button at the top left corner to return to the dashboard of the Davey Lifeguard app (ref figure 8.56).



Figure 8.56

8.3. SALT LOW WARNING

The Davey Lifeguard registers conductivity from the salt probe (or from within the chlorinator cell if salt probe not connected). Low conductivity could be triggered by cold water (below 15°C), a salt concentration below its minimum, or a cell that's in need of cleaning. To confirm the salt level required, refer to the respective section of your Nipper's owner's manual. An electronic copy can be downloaded from www.bit.ly/nippercm. The Davey Lifeguard's **HOME SCREEN** shows the **SALT LOW WARNING**.

This can also be observed from the dashboard of the Lifeguard app.

Additional salt may be added to overcome a lower temperature. However, the maximum salt level should also be considered and if water temperature drops too far, the system should be turned off.

Once the salt concentration is back within range (refer to recommended salt range section in the manual), the Davey Lifeguard will resume normal operation.

8.4. SALT LOW ALARM

Should the salt concentration continue to be diluted, the Lifeguard will enter **SALT LOW ALARM**.

The Lifeguard's **HOME SCREEN** shows the **SALT LOW ALARM**.

This can also be observed from the dashboard of the Lifeguard app.

Once the salt concentration is back within range (refer to recommended salt range section in the manual), the Davey Lifeguard will resume normal operation.

It is the responsibility of the user to maintain salt levels within the recommended range. Any damage caused by low salt will not be covered by warranty.

9. ADVANCED FEATURES

There are several advanced features available in the Davey Lifeguard. These modes can be found in the main menu (Figure 9.1). For any modes to be active the Davey Lifeguard must be on.



Figure 9.1

9.1 VSD SET POINT

The Lifeguard controller can control the speed of your connected circulation pump (if compatible. The Davey ProMaster PM400BT pool pump is an example of a compatible pump). To correctly operate the VSD pool pump control, ensure that the compatible pump is wired into the Lifeguard controller (refer Section 4.6.3).

9.1.1. Adjusting VSD set point on Davey Lifeguard control panel



- From the **HOME SCREEN**, press the . Press the  to scroll down to **SETTINGS** (ref Figure 9.2), then select by pressing the .



Figure 9.2

- Press the  to scroll down to **VSD SET POINT** (ref Figure 9.3), then select by pressing the .



Figure 9.3





- You will be asked if a compatible VSD pump is connected. Use the  to toggle YES/NO when appropriate (refer Figure 9.4) and then pressing the .



Figure 9.4

- The current speed setting will be shown next (refer Figure 9.5). Use the  menu up/down buttons scroll the speed setting between 20%, 40%, 60%, 80% and 100%, then press the  menu/setting select button to confirm.

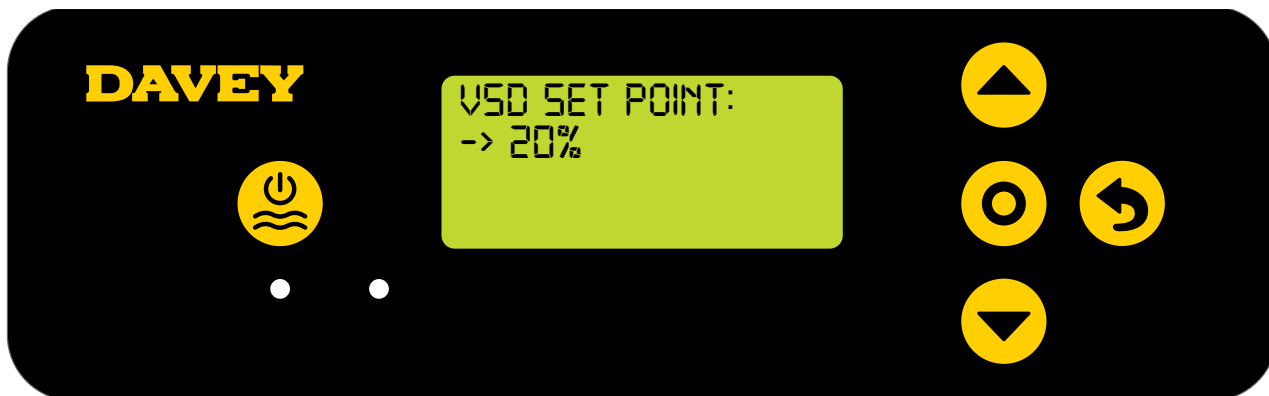

Figure 9.5

9.2 SYSTEM MODE

Consider this setting as “manual (override) on” and “standby”. When set to “SYSTEM ON”, the home screen will display “SYSTEM ON” (refer Figure 9.6). The pH and ORP control will operate normally, but the circulating pump (if powered by Nipper) will run continuously.

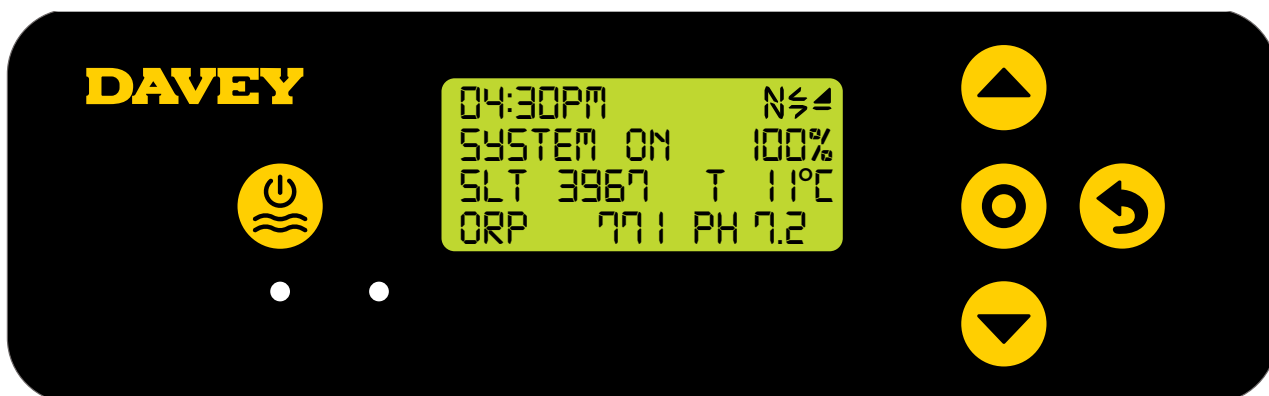

Figure 9.6

When set to “SYSTEM OFF”, the home screen will still display dashes where the last recorded probe readings were (refer Figure 9.6), and the circulating pump will not run. Nor will the salt cell produce Chlorine, or acid dosing pump feed acid.

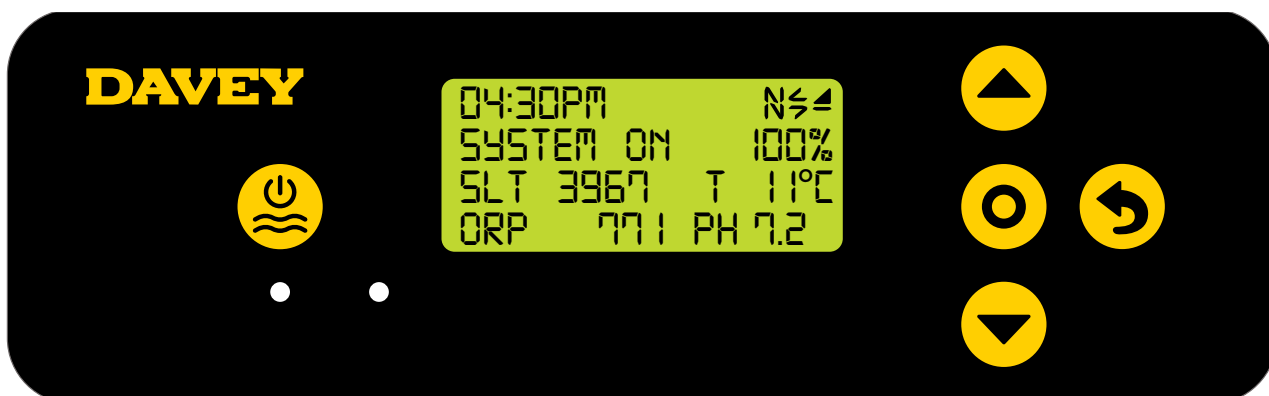

Figure 9.7

When set to “SYSTEM OFF”, the home screen will still display dashes where the last recorded probe readings were (refer Figure 9.8), and the circulating pump will not run. Nor will the salt cell produce Chlorine, or acid dosing pump feed acid.

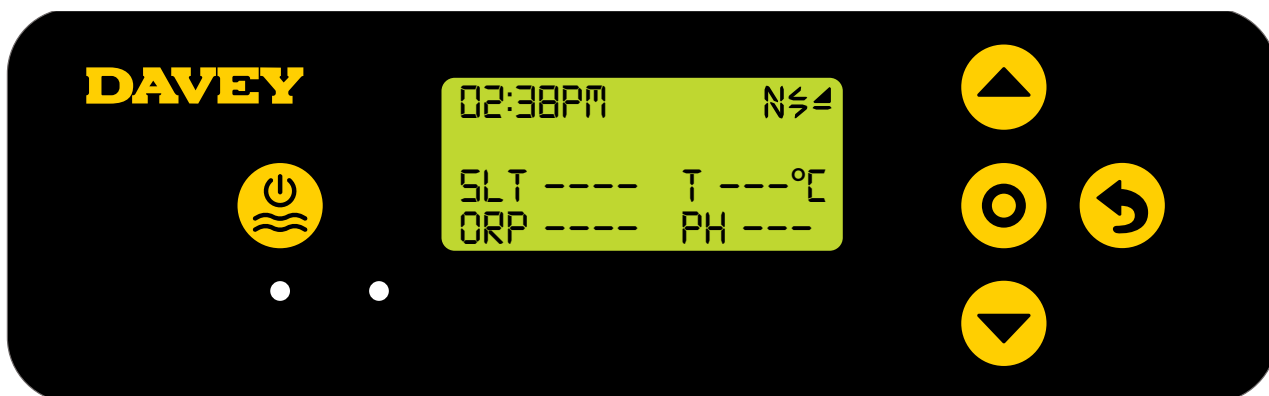

Figure 9.8

9.2.1. Activating system mode on Davey Lifeguard control panel

- System Mode can change between System on or off by pressing the manual on/off button from the **HOME SCREEN** or via the Modes section in settings.
- From the **HOME SCREEN**, press the menu/setting select button and go into MODES (refer Figure 9.9).



Figure 9.9

- From the MODES menu, select SYSTEM (refer Figure 9.10).

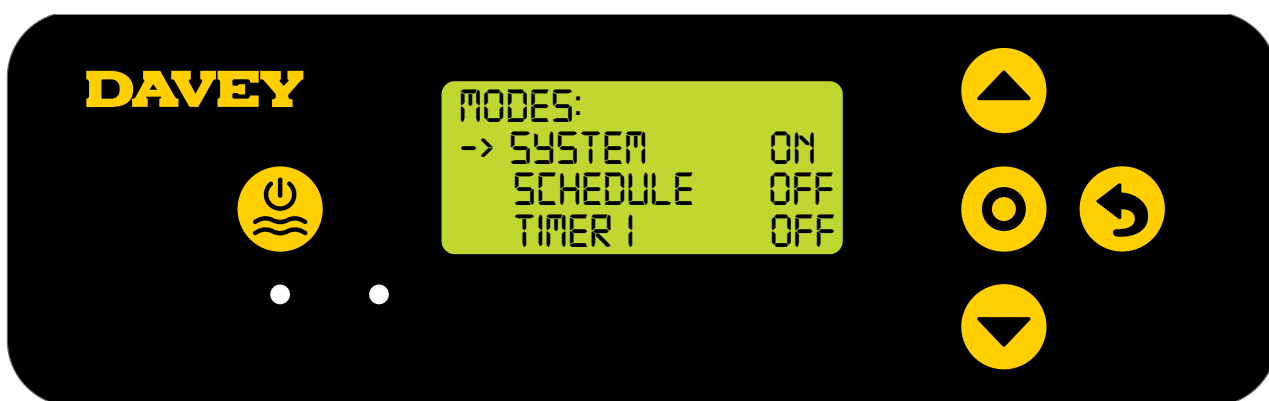

Figure 9.10

- The setting can be ON, or OFF. Use the menu up/down buttons to toggle YES/NO depending on your needs (refer Figure 9.11). Then press the menu/setting select button to confirm.

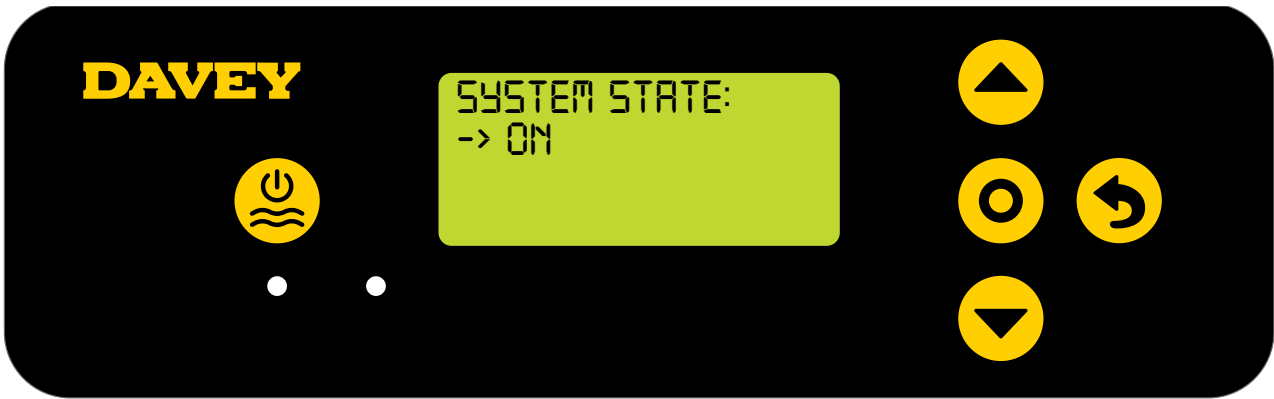

Figure 9.11

9.2.2. Activating system mode on Davey App

- From the dashboard of the Davey Lifeguard app, go to the “modes” menu by using the modes button (refer Figure 9.12).



Figure 9.12

- In the “modes” menu, manual mode can be toggled on (as shown), or off by simply sliding the switch (ref Figure 9.13).

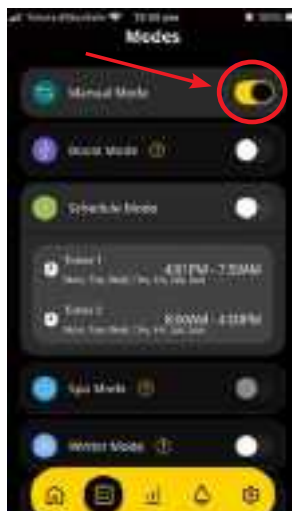

Figure 9.13

- You can now return to the dashboard by using the home button (refer Figure 9.14).



Figure 9.14

9.3 SCHEDULE MODE

Schedule mode allows the Lifeguard to run the system at specific times of the day. It also enables your circulation pump to run at selected speeds, during specific times of the day (if compatible – refer Section 9.1). This could be particularly handy if you wish to run your pump (for example):

- on a low speed during the night, to keep noise levels down; but
- want it running faster in the morning to skim leaves from the pool surface.

Turning Schedule mode to on requires at least one timer to be set and turned on (refer Section 9.3.1). To operate correctly, Schedule mode requires System mode to be turned off (see Section 9.2).

9.3.1. Adjusting Schedule Mode on Davey Lifeguard control panel

9.3.1.1. Adding a timer

- From the **HOME SCREEN**, press the  **menu/setting select** button and go into **MODES** (refer Figure 9.15).

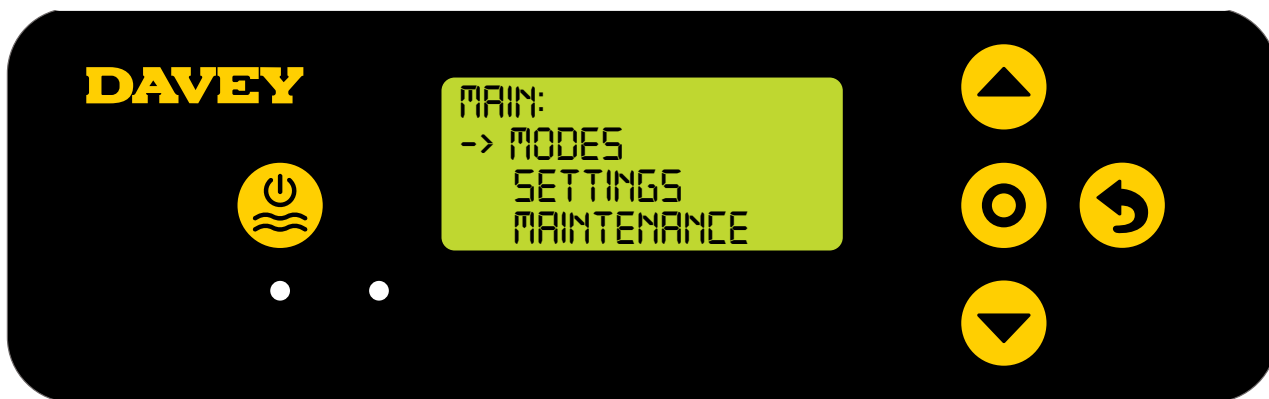

Figure 9.15

- From the **MODES** menu, select **TIMER 1** (refer Figure 9.16).

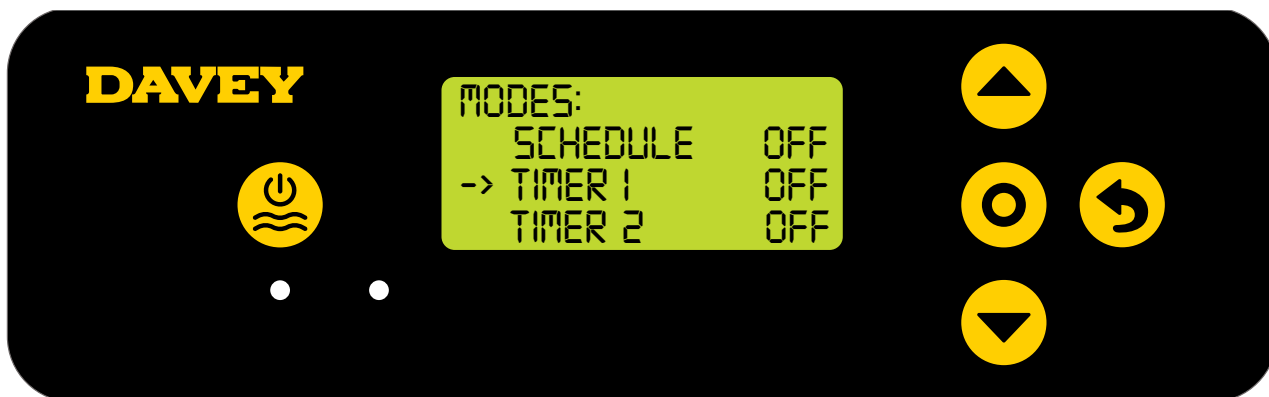

Figure 9.16

- From the TIMER 1 menu use the  menu up/down buttons to scroll down and select EDIT (refer Figure 9.17).



Figure 9.17

- From the TIMER 1 menu, you will be asked to select a speed you wish to run your VSD pump at, during this specific time (refer Figure 9.18). If you do not have a compatible pump connected, or you have not set your VSD speed control (refer Section 9.1), skip this step.



Figure 9.18

- Next, you will be asked to select the TIMER 1 ON time (refer Figure 9.19). Adjust this time setting as you adjusted clock settings for first time setup (refer Section 6.3).



Figure 9.19

- Next, you will be asked to select a TIMER 1 OFF time (refer Figure 9.20). Adjust this time setting as before.



Figure 9.20

- Once time settings have been made to TIMER 1, press the  menu/setting select button to re-enter the TIMER 1 menu (refer Figure 9.21).



Figure 9.21





- Use the  menu up/down buttons to scroll down to ON (refer Figure 9.22).



Figure 9.22

- Then press the  menu/setting select button to confirm. This process can be replicated for TIMER 2.

9.3.1.2. Activating Schedule Mode

- Schedule Mode can change between Schedule on or off by pressing the  manual on/off button from the **HOME SCREEN** or via the Modes section in settings.
- From the **HOME SCREEN**, press the  menu/setting select button and go into MODES (refer Figure 9.23).

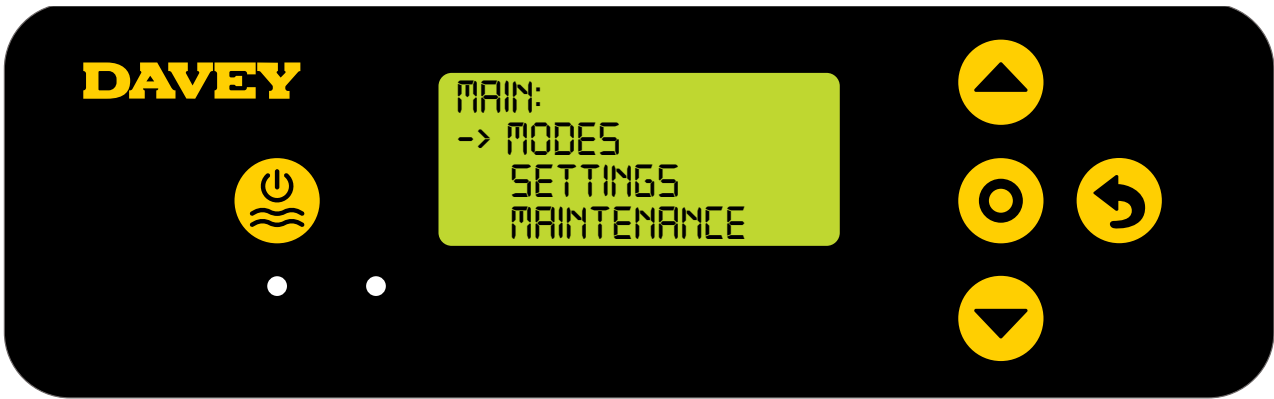

Figure 9.23

- From the MODES menu, use the ▲▼ menu up/down buttons to scroll down to SCHEDULE (refer Figure 9.24). Then press the ⓪ menu/setting select button to confirm.

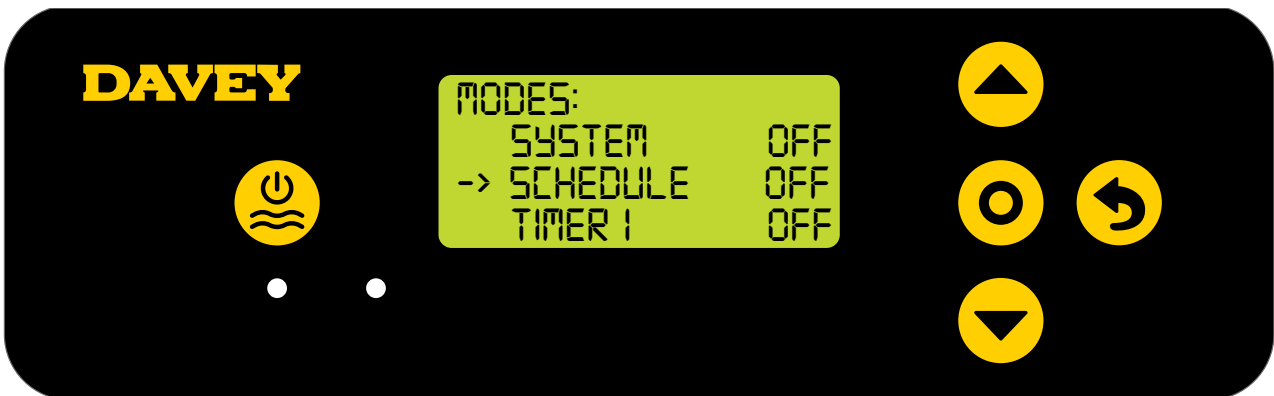

Figure 9.24

- Use the ▲▼ menu up/down buttons to toggle ON/OFF as required (refer Figure 9.25). Then press the ⓪ menu/setting select button to confirm.

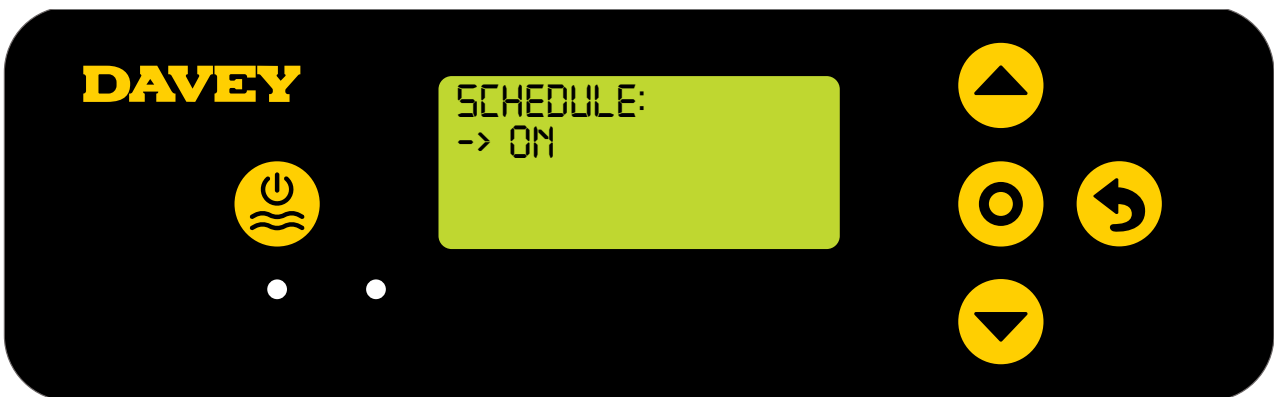

Figure 9.25

- As a reminder, to correctly operate schedule mode, there must be at least one timer set and turned on (refer Section 9.3 and Figure 9.26).

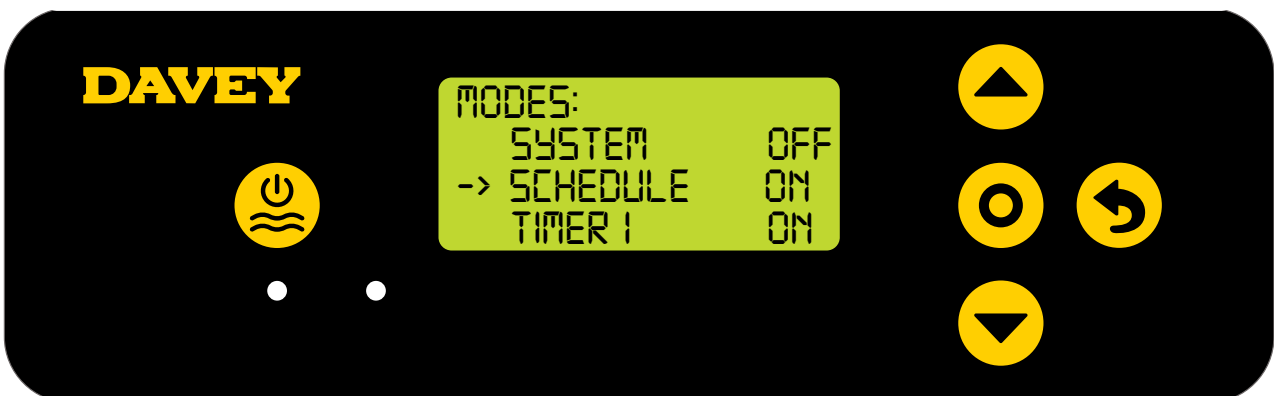

Figure 9.26

9.3.2.Adjusting Schedule Mode on Davey App

9.3.2.1. Adding a timer

- From the dashboard, go to the “modes” menu by using the modes button (refer Figure 9.27).



Figure 9.27

- In the “modes” menu, click the “Add Timer” button (refer Figure 9.28).

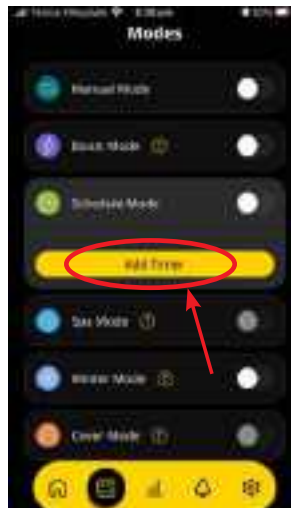

Figure 9.28

- The first time to set will be the start time for your timer. You can see this as the “Start Time” field is highlighted yellow initially (refer Figure 9.29). Consider this as the time you want the system to turn on. If you have compatible equipment, you can also elect a pump run speed, for this timer (refer Section 9.1). You can also elect to turn on/off your heat pump (refer Section 9.11).

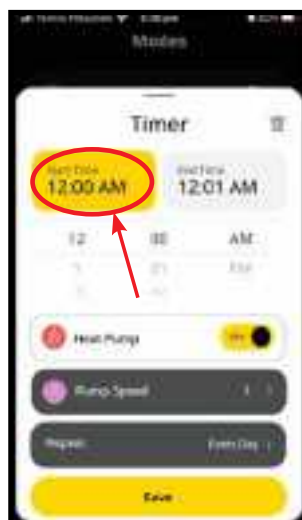

Figure 9.29

- Adjustments can be made to the scheduled start time by scrolling the hours &/or minutes up and down with your finger on the screen (refer Figure 9.30).

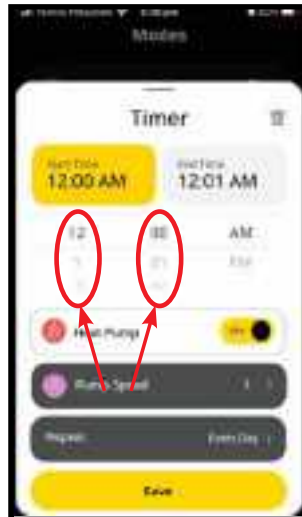

Figure 9.30

- To set the end time, first ensure you push the “End Time” button (refer Figure 9.31), then adjust the time as above.

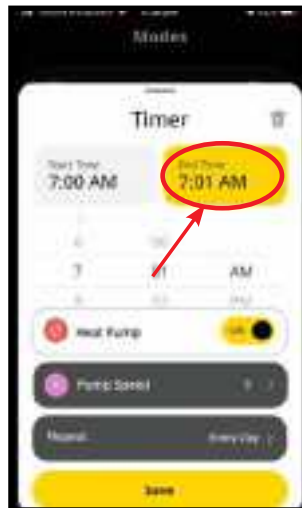

Figure 9.31

- To save the timers you’ve set, simply click save at the bottom of the screen. You can now return to the dashboard by using the home button (refer Figure 9.32), or activate Schedule Mode (refer Section 9.3.2.3).

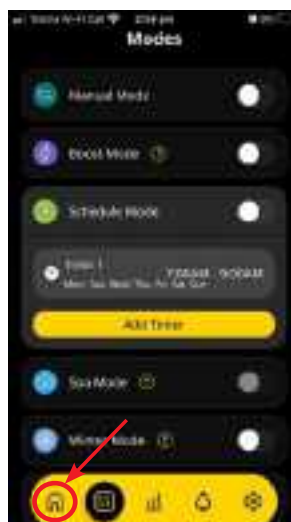

Figure 9.32

- Should you wish to add two separate timers, repeat the process above. They will appear in the Modes menu as shown (ref Figure 9.33).

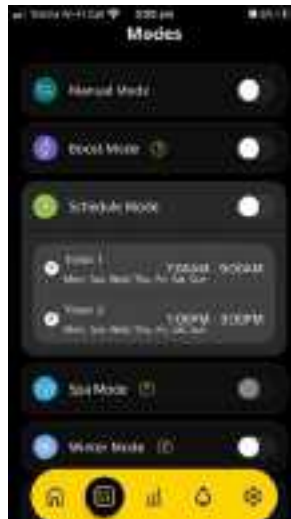

Figure 9.33

9.3.2.2. Removing a timer

- From the dashboard, go to the “modes” menu by using the modes button (refer Figure 9.34).



Figure 9.34

- In the “modes” menu, click the timer you wish to remove (refer Figure 9.35).

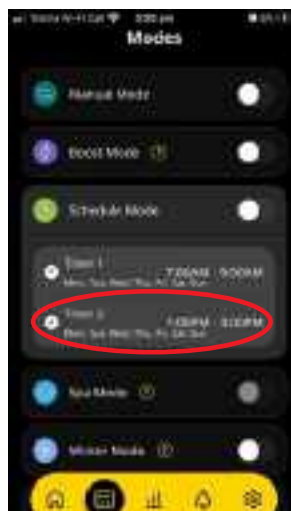

Figure 9.35

- Once a specific timer has been chosen, push the trash can logo on the right of the screen (refer Figure 9.36).

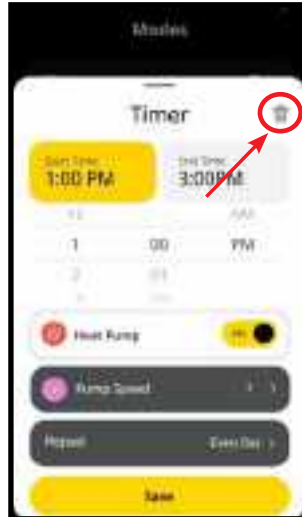

Figure 9.36

- The Modes screen should no longer show that specific timer. You can now return to the dashboard by using the home button (refer Figure 9.37).

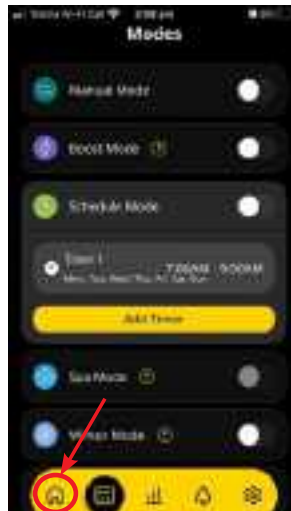

Figure 9.37

9.3.2.3. Activating Schedule Mode

- Ensure Manual Mode is off (refer Section 9.2). To activate system mode, go to the “modes” menu by using the modes button (refer Figure 9.38).



Figure 9.38

- Schedule Mode can now be toggled on/off by simply sliding the switch (ref Figure 9.39).

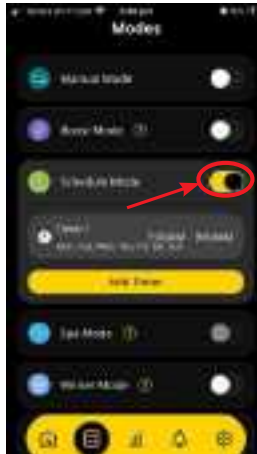

Figure 9.39

- You can now return to the dashboard by using the home button (refer Figure 9.40).

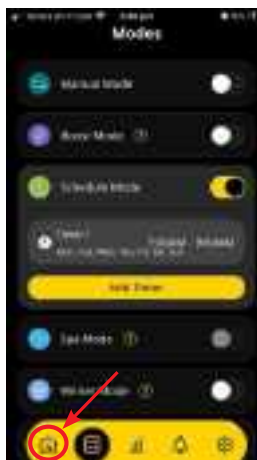

Figure 9.40





9.4 BOOST MODE

Should the pool experience a heavy bather load, debris/contamination, or extreme warm weather, there may be a need to super-chlorinate the pool. Turning on the **BOOST MODE** increases the chlorinator cell duty cycle to 100% and overrides the cell current (output) to 100% for a period of 24 hours.



Probes aren't resistant to high levels of chlorine for extended periods of time as it may reduce the life of the probe. Davey recommends removing the probes from the manifold when increasing chlorine in the pool.

9.4.1. Activating Boost Mode on Davey Lifeguard control panel

- From the **HOME SCREEN**, press the  **menu/setting select** button. Press the   **menu up/down** buttons to scroll down to **MODES** (ref Figure 9.41), then select by pressing the  **menu/setting select** button.

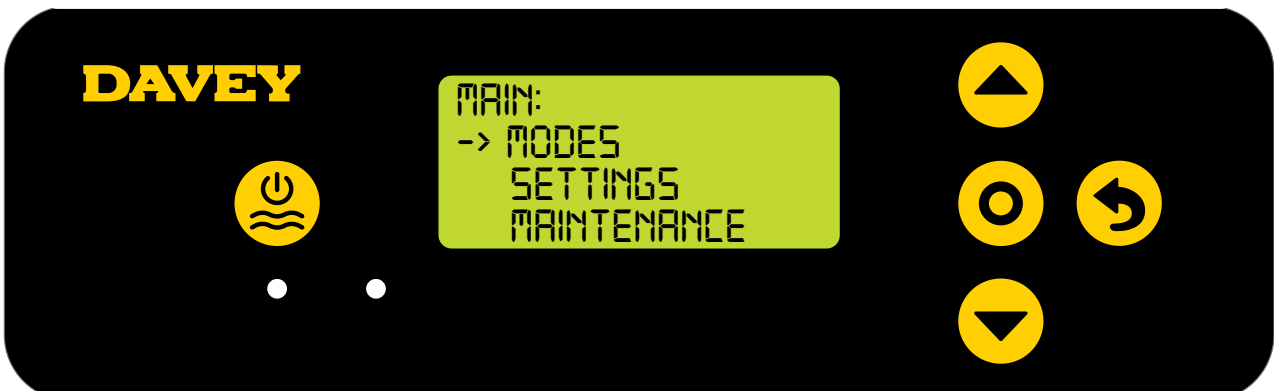

Figure 9.41

- Press the ▲▼ menu up/down buttons to scroll down to **BOOST** (ref Figure 9.42), then select by pressing the ● menu/setting select button.



Figure 9.42

- Boost mode can now be toggled ON/OFF where appropriate by using the ▲▼ menu up/down buttons (ref Figure 9.43), then select by pressing the ● menu/setting select button.



Figure 9.43

- Press the ↶ menu/setting cancel (go back) button twice to revert back to the **HOME SCREEN** (refer Figure 9.44).

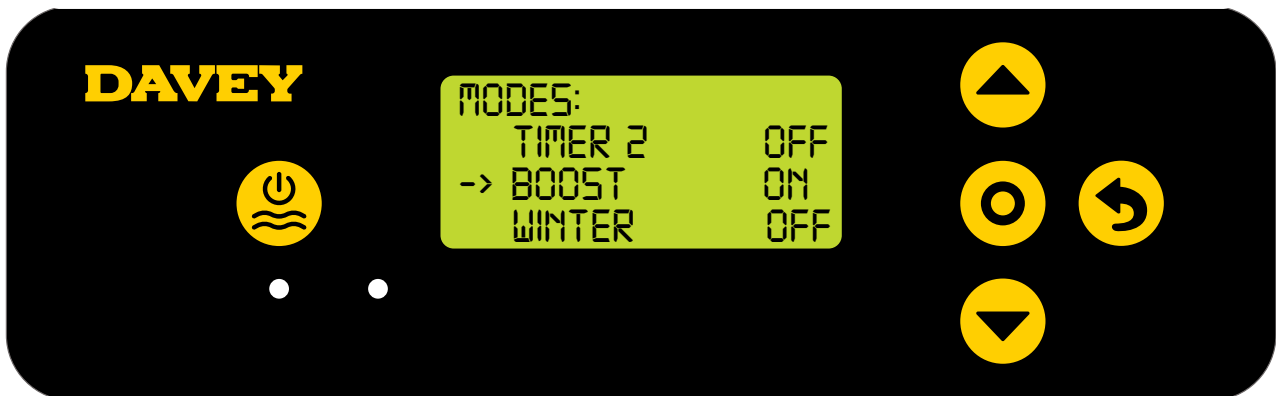

Figure 9.44

- Once back at the **HOME SCREEN** the display will toggle to show BOOST ON (refer Figure 9.45).

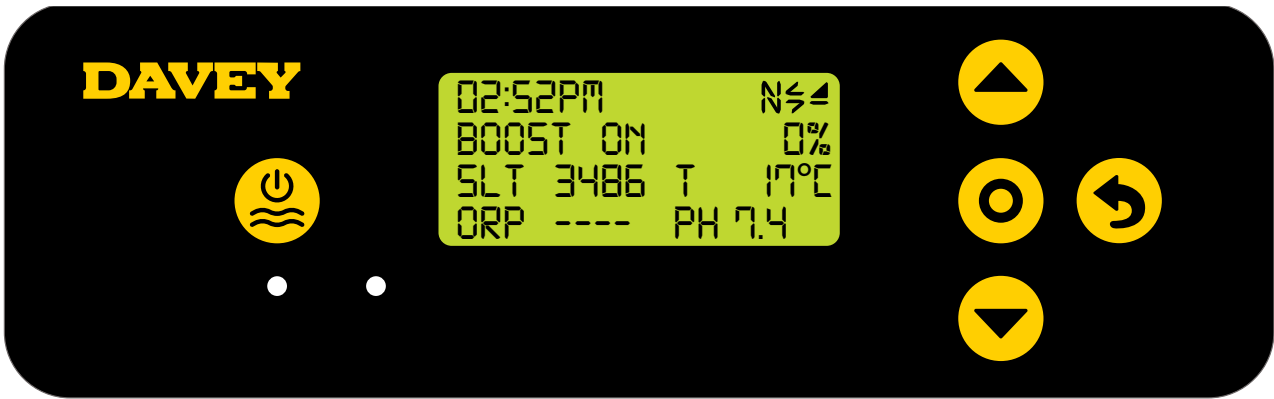

Figure 9.45

- To turn off **BOOST MODE**, repeat the process shown above, but opt for “**BOOST MODE: OFF**”.

9.4.2. Activating Boost Mode on Davey App

- From the dashboard of the Davey Lifeguard app, go to the “modes” menu by using the modes button (refer Figure 9.46).



Figure 9.46

- In the “modes” menu, **BOOST MODE** can be toggled on, or off by simply sliding the switch (ref Figure 9.47).

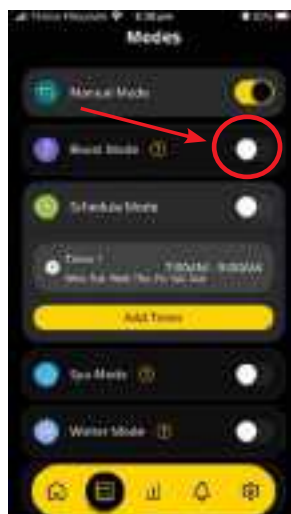

Figure 9.47

- Return to the dashboard now by using the home button (refer Figure 9.48).



Figure 9.48

- Once back at the dashboard “Boost Mode Active” will now appear (refer Figure 9.49).



Figure 9.49

- To turn off **BOOST MODE**, repeat the process shown above, but opt for “**BOOST MODE: OFF**”.

9.5 WINTER MODE

During winter months the conductivity is affected by low water temperatures, this can have a significant effect on the life of cell. There is also typically less chlorine demand as the pool is not likely to be used.

WINTER MODE reduces the cell current across the cell plates to 85% to protect the cell and allow the ability to run in low conductivity conditions.

For example:

- When the Lifeguard is running the Nipper Chlorinator and **WINTER MODE** is off. The chlorinator cell current (typically measured in Amps) will be operating at 100% capacity;
- However, when Lifeguard is running the Nipper chlorinator, but **WINTER MODE** is on: the chlorinator cell current (typically measured in Amps) will only be operating at 85% capacity.

9.5.1. Activating Winter Mode on Davey Lifeguard control panel

- From the **HOME SCREEN**, press the **ⓘ** menu/setting select button. Press the **▲▼** menu up/down buttons to scroll down to **MODES** (ref Figure 9.50), then select by pressing the **ⓘ** menu/setting select button.



Figure 9.50

- Press the **▲▼** menu up/down buttons to scroll down to **WINTER** (ref Figure 9.51), then select by pressing the **ⓘ** menu/setting select button.



Figure 9.51

- WINTER MODE** can now be toggled ON/OFF where appropriate by using the **▲▼** menu up/down buttons (ref Figure 9.52), then select by pressing the **ⓘ** menu/setting select button.



Figure 9.52

- Press the  menu/setting cancel (go back) button twice to revert back to the **HOME SCREEN** (refer Figure 9.53).

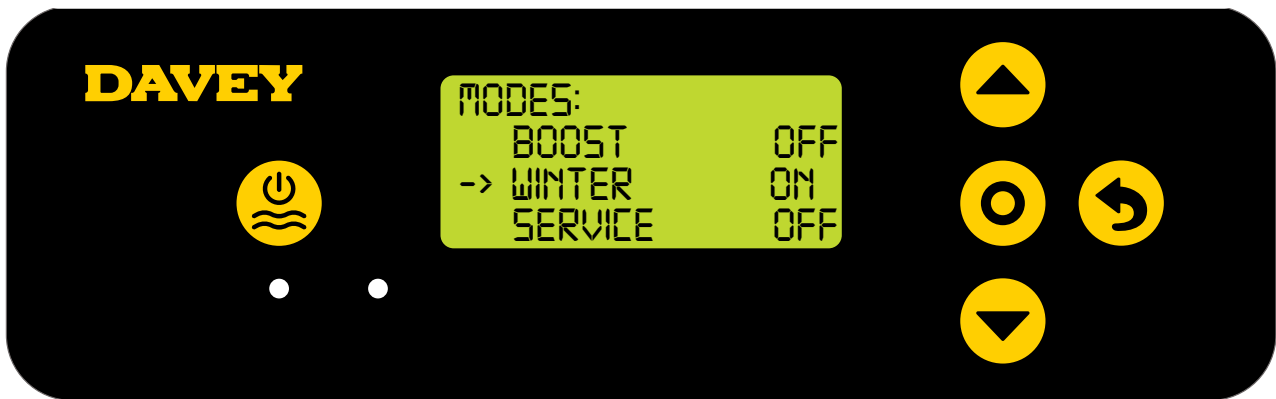

Figure 9.53

- Once back at the **HOME SCREEN** the display will toggle to show **WINTER ON** (refer Figure 9.54).



Figure 9.54

- To turn off **WINTER MODE**, repeat the process shown above, but opt for “**WINTER MODE: OFF**”.

9.5.2. Activating Winter Mode on Davey App

- From the dashboard, go to the “modes” menu by using the modes button (refer Figure 9.55).



Figure 9.55

- In the “modes” menu, **WINTER MODE** can be toggled on, or off by simply sliding the switch (ref Figure 9.56).

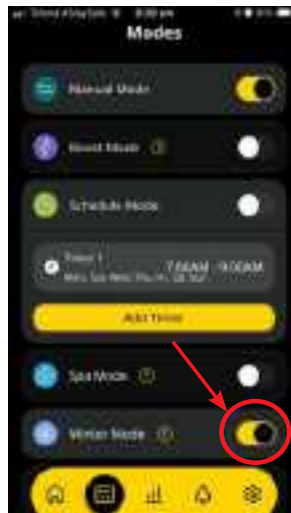

Figure 9.56

- Return to the dashboard now by using the home button (refer Figure 9.57).



Figure 9.57

- Once back at the dashboard “Winter Mode Active” will now appear (refer Figure 9.58).



Figure 9.58

- To turn off **WINTER MODE**, repeat the process shown above, but opt for “**WINTER MODE: OFF**”.

9.6 SERVICE MODE

The service mode menu is only accessed by the manufacturer &/or it's Authorised Service Representatives.

9.7 BACKWASH MODE

When using a media filter, there will occasionally come a need to backwash the pool's filter. During the backwash process, water is typically expelled from the pool's filter, out to waste (rather than through the salt cell & back to the pool). The backwash mode in Lifeguard disables the Lifeguard app, to ensure that the pumps are only turned on & off (during the maintenance), by the person operating the controller. In addition, backwash mode automatically triggers the pool pump (if compatible – refer Section 9.1) to vary the speed of its motor & fluctuate the flow of water through the media bed. This enables a more thorough clean of the media & ultimately a more effective backwash, using less water.

9.7.1. Adjusting backwash mode on the Davey Lifeguard control panel

If you plan to run a backwash of a media filter, first switch the system to SYSTEM OFF (refer Section 9.2). Also ensure that the pump is not set to come on again via any means, remote or otherwise (refer Section 9.3). Then turn your media filter to backwash setting.

- From the **HOME SCREEN**, press the  **menu/setting select** button and go into MODES (refer Figure 9.59).



Figure 9.59

- From the MODES menu, use the  **menu up/down** buttons to scroll down to BACKWASH (refer Figure 9.60).

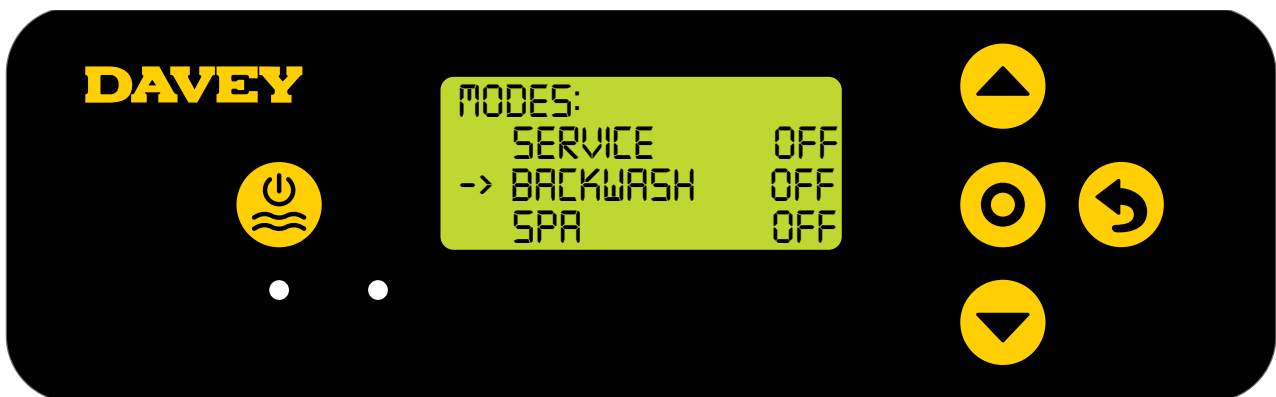

Figure 9.60

- In the backwash menu, use the  **menu up/down** buttons to toggle ON/OFF as required (refer Figure 9.61). Then press the  **menu/setting select** button to confirm.

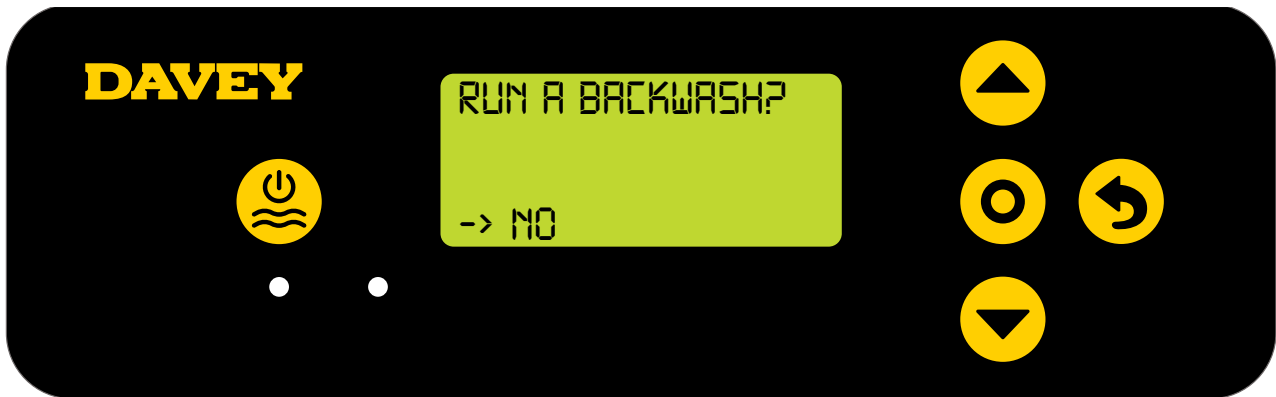

Figure 9.61

- The pump will turn on and in the case of a compatible pump (refer Section 9.1), the flow will begin to vary as the motor speeds up and slows down. During this time, the probes will not show a reading (refer Figure 9.62) as water will be passing from the pool filter to waste. This will continue for ~ 2 minutes. The pump will then stop.



Figure 9.62

- If the sight glass of your media filter was yet to clear in that period, repeat the steps above for another 2-minute cycle. If the sight glass did clear, turn your media filter to rinse setting and allow the pump to run again for another 2-minute cycle. When the pump again stops, your filter can be returned to its normal/ filter setting.

Lifeguard BACKWASH mode should now be returned to normal (refer Figure 9.63), following the steps above.

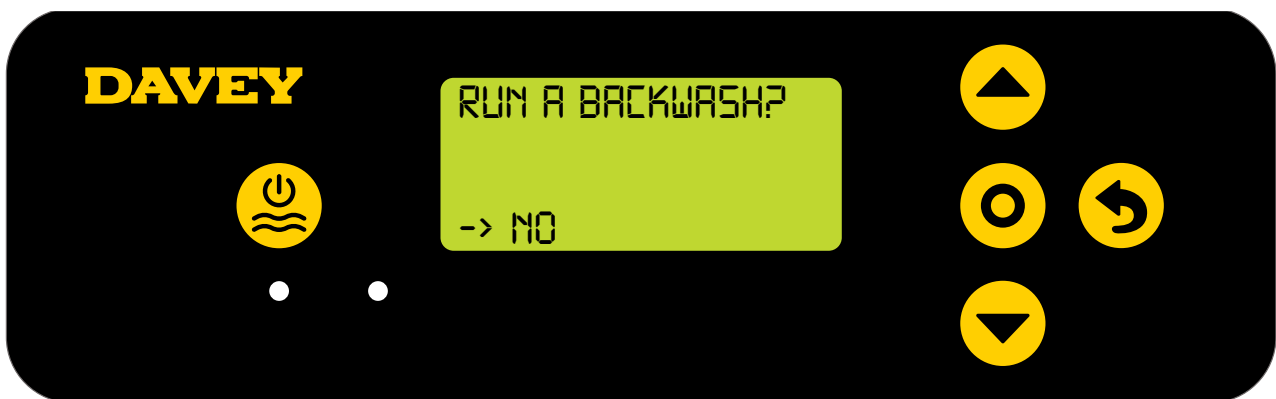

Figure 9.63

- You can now turn back on the system, either by SYSTEM ON (refer Section 9.2), or by SCHEDULE ON (refer Section 9.3).

9.7.2. Adjusting backwash mode on the app

Backwash mode control is not available via the app and must be controlled by the Lifeguard control panel. This ensures that the operator is present, with the pool equipment during the maintenance.

9.8 SPA MODE (for use if NO ORP probe is connected)

The Davey Lifeguard is compatible with large swimming pool applications as well as much smaller spa applications. Turning on the **SPA MODE** reduces the chlorinator cell duty cycle by 80% of its current setting.

For example:

- If the Nipper is on for 10 hours per day, the **CHLORINE OUTPUT** is set to 50%, but the **SPA MODE** is off: the Nipper cell duty cycle is 5 hours of that day.
- However, if the Nipper is on for 10 hours per day, the **CHLORINE OUTPUT** is set to 50%, and **SPA MODE** is on: the Nipper cell duty cycle is only 1 hour of that day.
- Similarly, if the Nipper is on for 10 hours per day, the **CHLORINE OUTPUT** is set to 25%, and **SPA MODE** is on: the Nipper cell duty cycle is only 30 minutes of that day.

Reminder: **SPA MODE** can only be selected from the menu if ORP probe is not connected.

9.8.1. Activating Spa Mode on Davey Lifeguard control panel





- From the **HOME SCREEN**, press the  **menu/setting select** button. Press the  **menu up/down** buttons to scroll down to **MODES** (ref Figure 9.65), then select by pressing the  **menu/setting select** button.



Figure 9.65

- Press the  **menu up/down** buttons to scroll down to **SPA** (ref Figure 9.66), then select by pressing the  **menu/setting select** button.

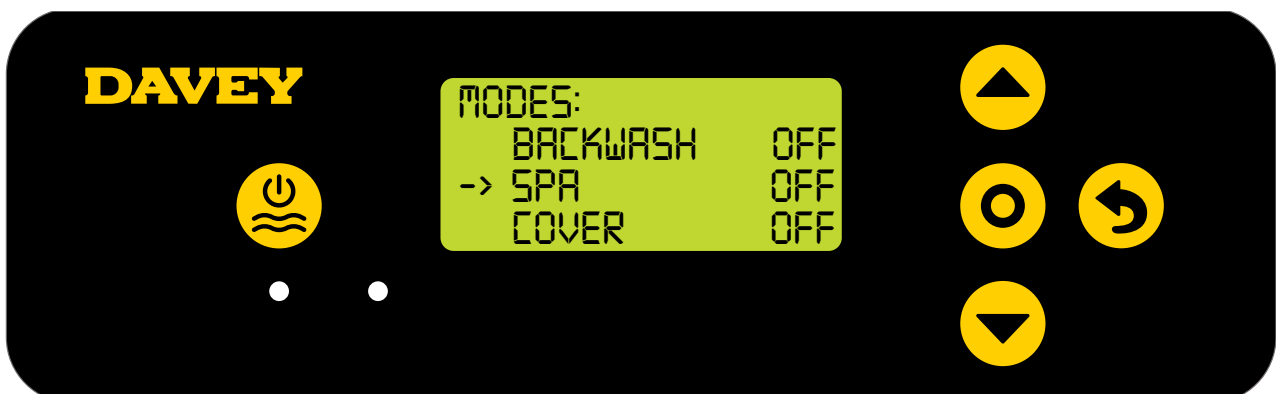



Figure 9.66

- SPA mode can now be toggled ON/OFF where appropriate by using the  menu up/down buttons (ref Figure 9.67), then select by pressing the  menu/setting select button.



Figure 9.67

- Press the  menu/setting cancel (go back) button twice to revert back to the HOME SCREEN (refer Figure 9.68).

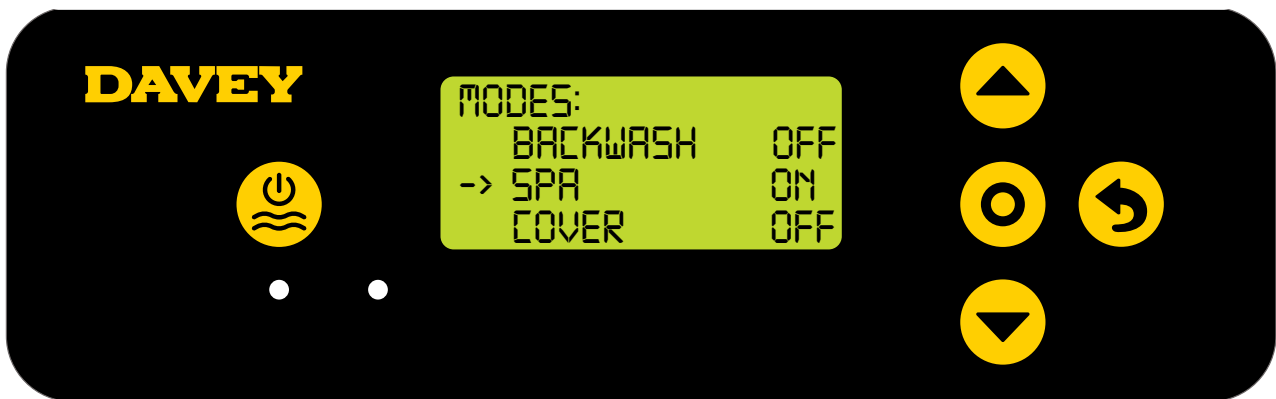

Figure 9.68

- Once back at the HOME SCREEN the display will toggle to show SPA ON (refer Figure 9.69).

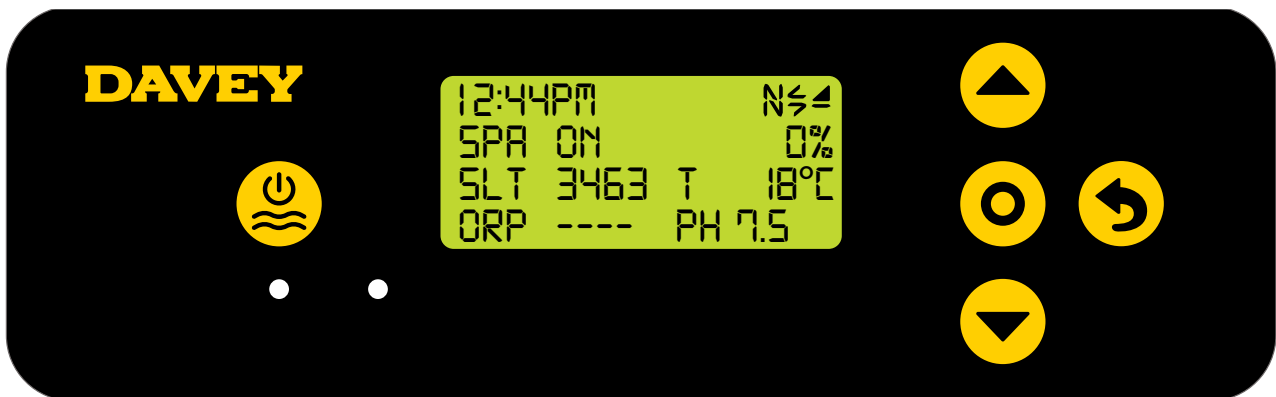

Figure 9.69

- To turn off **SPA MODE**, repeat the process shown above, but opt for “SPA MODE: OFF”.

9.8.2. Activating Spa Mode on Davey App

- From the dashboard of the Davey Lifeguard app, go to the “modes” menu by using the modes button (refer Figure 9.70).



Figure 9.70

- In the “modes” menu, **SPA MODE** can be toggled on, or off by simply sliding the switch (ref Figure 9.71).

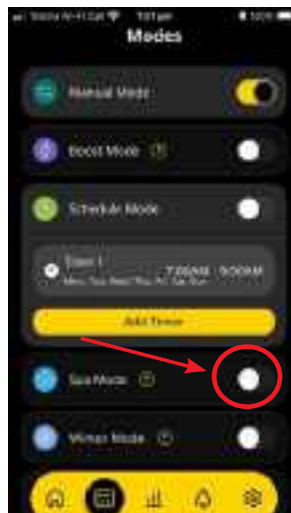

Figure 9.71

- Return to the dashboard now by using the home button (refer Figure 9.72).

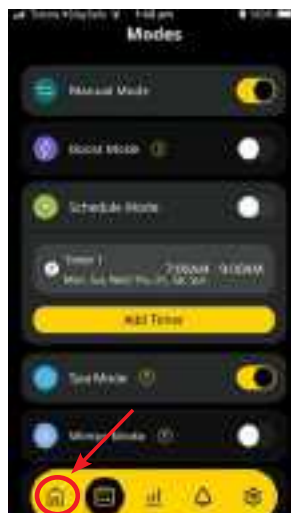

Figure 9.72

- Once back at the dashboard “Boost Mode Active” will now appear (refer Figure 9.73).



Figure 9.73

- To turn off **SPA MODE**, repeat the process shown above, but opt for “**SPA MODE: OFF**”.

9.9 COVER MODE (for use if NO ORP probe is connected):

The Davey Lifeguard is compatible with large swimming pool applications as well as much smaller spa applications. Turning on the **COVER MODE** reduces the chlorinator cell duty cycle by 80% of its current setting.

For example:

- If the Nipper is on for 10 hours per day, the **CHLORINE OUTPUT** is set to 50%, and **COVER MODE** is off: the Nipper cell duty cycle is 5 hours of that day.
- However, if the Nipper is on for 10 hours per day, the **CHLORINE OUTPUT** is set to 50%, and **COVER MODE** is on: the Nipper cell duty cycle is only 1 hour of that day.
- Similarly, if the Nipper is on for 10 hours per day, the **CHLORINE OUTPUT** is set to 25%, and **COVER MODE** is on: the Nipper cell duty cycle is only 30 minutes of that day.

Reminder: **COVER MODE** can only be selected from the menu if ORP probe is not connected.

9.9.1. Activating Cover Mode on Davey Lifeguard control panel





- From the **HOME SCREEN**, press the  **menu/setting select** button. Press the   **menu up/down** buttons to scroll down to **MODES** (ref Figure 9.74), then select by pressing the  **menu/setting select** button.



Figure 9.74

- Press the ▲▼ menu up/down buttons to scroll down to **COVER** (ref Figure 9.75), then select by pressing the Ⓞ menu/setting select button.

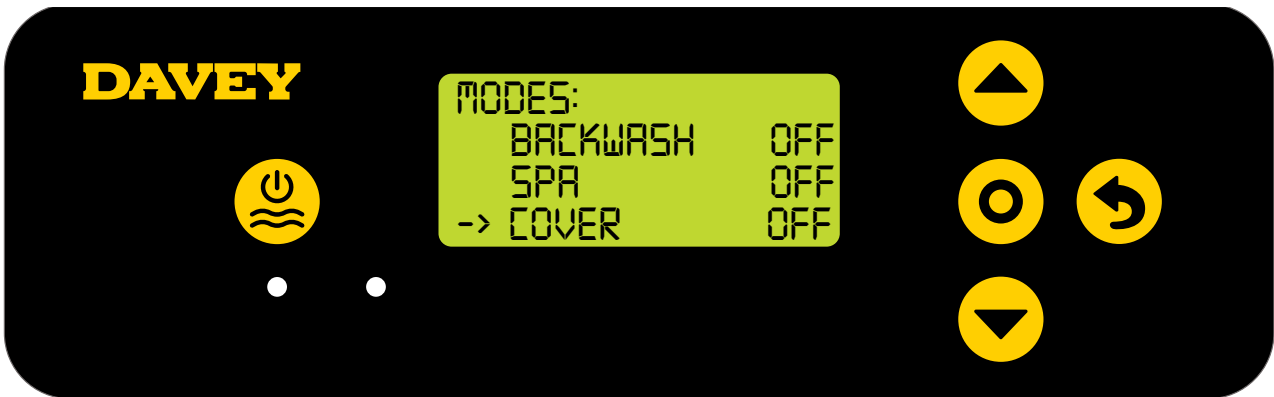

Figure 9.75

- **COVER MODE** can now be toggled ON/OFF where appropriate by using the ▲▼ menu up/down buttons (ref Figure 9.76), then select by pressing the Ⓞ menu/setting select button.

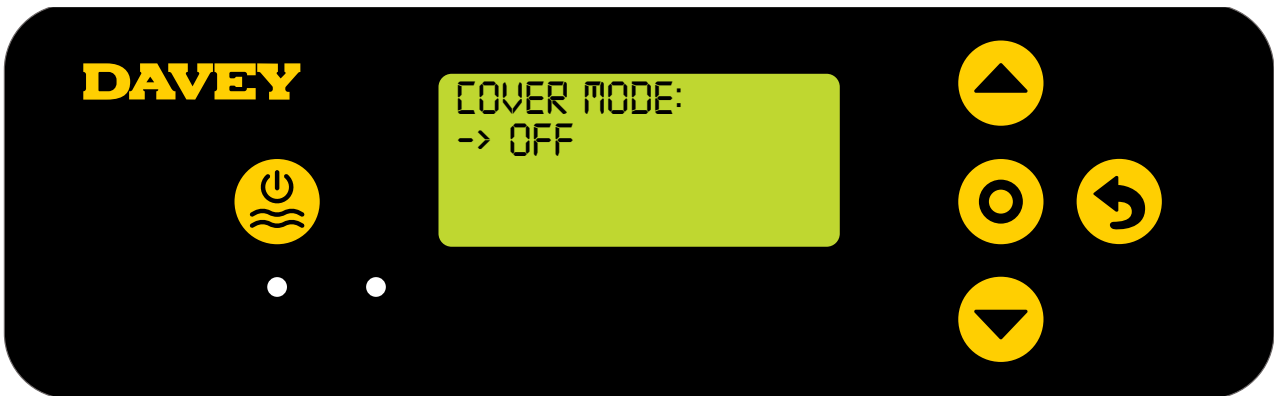

Figure 9.76

- Press the ↶ menu/setting cancel (go back) button twice to revert back to the **HOME SCREEN** (refer Figure 9.77).

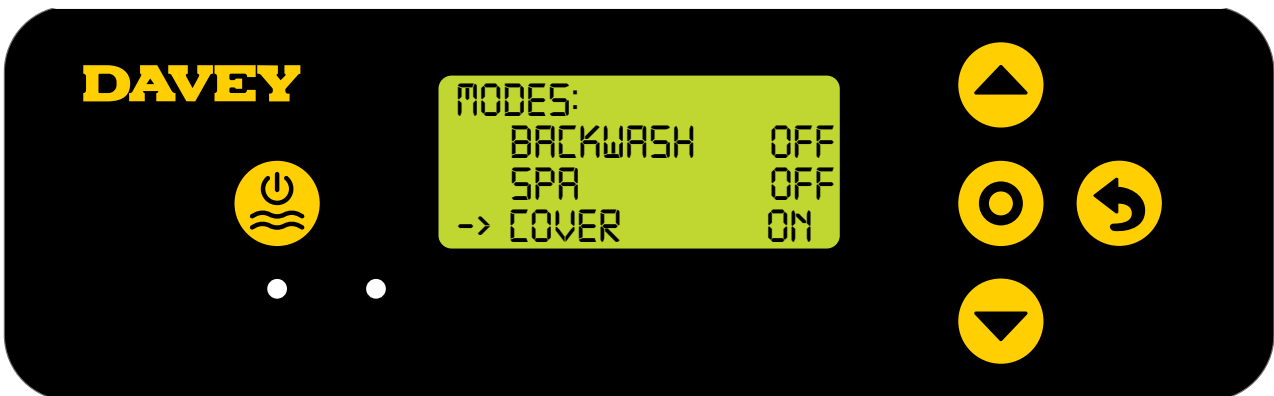

Figure 9.77

- Once back at the **HOME SCREEN** the display will toggle to show SPA ON (refer Figure 9.78).

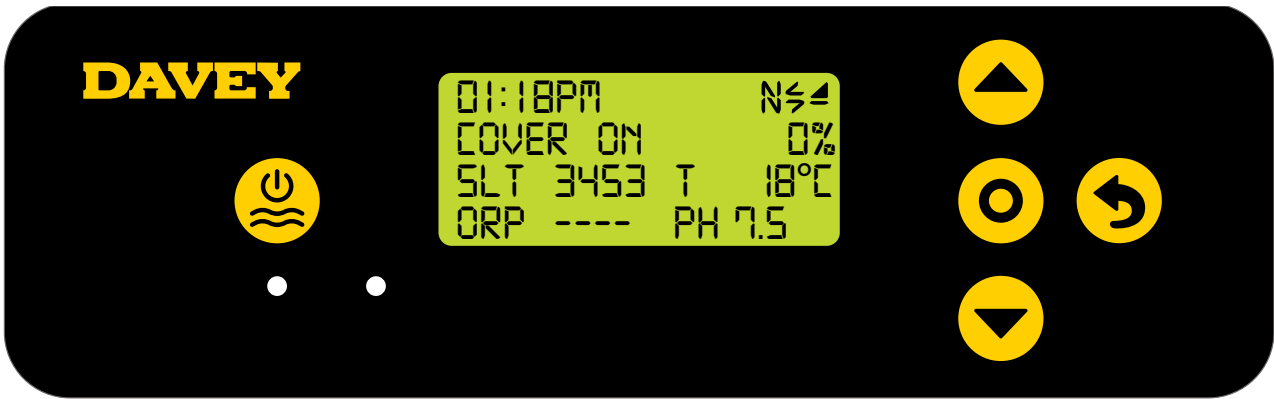

Figure 9.78

- To turn off **COVER MODE**, repeat the process shown above, but opt for “**COVER MODE: OFF**”.

9.9.2. Activating Cover Mode on Davey App

- From the dashboard, go to the “modes” menu by using the modes button (refer Figure 9.79).



Figure 9.79

- In the “modes” menu, scroll the screen to reveal COVER MODE. COVER MODE can be toggled on, or off by simply sliding the switch (ref Figure 9.80).

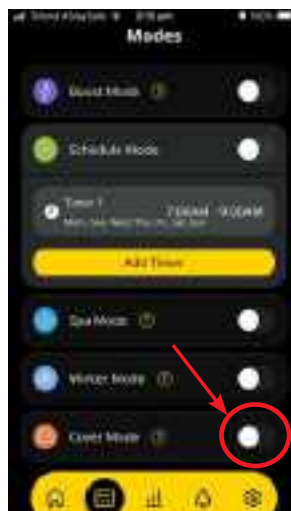

Figure 9.80

- Return to the dashboard now by using the home button (refer Figure 9.81).



Figure 9.81

- Once back at the dashboard “Cover Mode Active” will now appear (refer Figure 9.82).



Figure 9.82

- To turn off **COVER MODE**, repeat the process shown above, but opt for “**COVER MODE: OFF**”.

9.9.3. Activating Cover Mode remotely

- **COVER MODE** can also be triggered remotely by an automated pool cover controller. By closing the terminal block contacts on the rear of the Nipper power supply (ref Figure 9.83), Davey Lifeguard will remotely switch to **COVER MODE**. This can be overridden by user intervention, by following the steps explained previously.



Figure 9.83

9.10 SPA & COVER MODE (SIMULTANEOUS):

Should it be necessary to run **SPA MODE** and **COVER MODE** simultaneously, the chlorinator cell duty cycle is only reduced by 80%. That is, the cell duty cycle isn't reduced by 80%, followed by a further 80%. The **HOME SCREEN** display will toggle between showing **COVER** and **SPA**. As previously mentioned, neither **COVER**, or **SPA** mode is necessary when Davey Lifeguard is working with an ORP probe.

For example:

- If the Nipper is on for 8 hours per day, the **CHLORINE OUTPUT** is set to 50%, but the **COVER MODE** is on: the Nipper cell duty cycle is only 48 minutes, of that day;
- If the Nipper is on for 8 hours per day, the **CHLORINE OUTPUT** is set to 25%, but the **COVER MODE** is on: the Nipper cell duty cycle is only 24 minutes, of that day.

COVER MODE can also be triggered remotely by an automated pool cover controller. By closing the terminal block contacts on the rear of the Nipper power supply (ref figure 9.2), Davey Lifeguard will remotely switch to **COVER MODE**. This can be overridden by user intervention, by following the steps explained previously.

9.11 HEAT PUMP CONNECTION – “DAVEY HEAT PUMP”:

The Lifeguard app (not the controller itself) can control the set temperature of your connected pool heat pump (if it's a compatible model). The following models are examples of compatible heat pumps covered by this section. Some alternate models are covered by Section 9.12.

Davey Heat Pump models
DHP90
DHP130
DHP170
DHP210

The instructions for connecting the heat pumps do differ slightly depending on the model of heat pump you have. Please ensure you use the correct section following. The instructions for the Davey Heat Pump assumes that the heater is already turned on. Turning the heat pump on/off can not be controlled by the Lifeguard, only the temperature adjustment. The Heat pump will run automatically while the filtration cycle is on or while in manual mode and will show a flow alarm (E3 for DHP models) while not running, this is normal.

If you would like the heat pump not to run at all, you can isolate the power to the heat pump or set the temperature to 0°C.

9.11.1. Connecting Lifeguard to a “Davey Heat Pump”

- From the dashboard, go to the “settings” menu by using the modes button (refer Figure 9.84).



Figure 9.84

- Press the “Heat Pump” button (refer Figure 9.85).

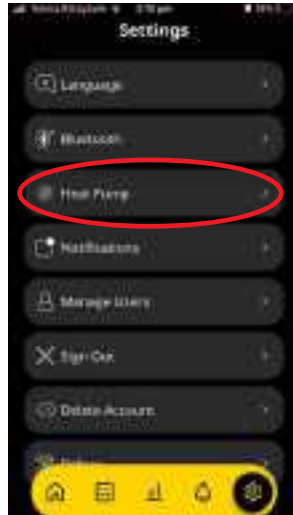

Figure 9.85

- If you are looking to sync a “Davey Heat Pump”, then press the respective button (refer Figure 9.86). If you are looking to sync a “Davey by Nirvana” heat pump, go to section 9.11.2 of this manual.

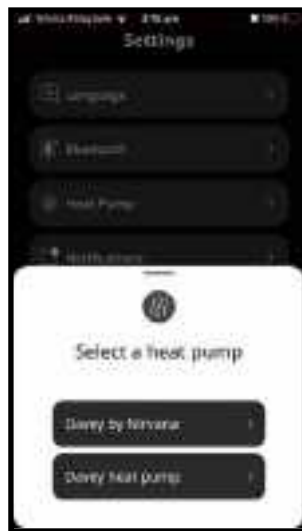

Figure 9.86

- It is important to ensure that your device is connected to the WiFi network you wish to use. This must be a 2.4GHz WiFi network, not a 5GHz WiFi network. To continue, simply press “Connect Now”. Alternatively, should you need to cancel, you can via the back button (refer Figure 9.87).

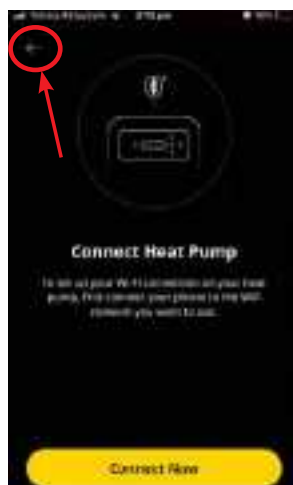

Figure 9.87

- Ensure the current network shown is the same network that your smart device is connected to. Enter the WiFi password now (refer Figure 9.88). Follow instructions relating to touchpad controls on the heat pump, before clicking “Connect Now”.



Figure 9.88

- Allow a couple of minutes to connect Lifeguard to your Davey Heat Pump. Your app will show the connection is in progress (refer Figure 9.89). This screen will continue for ~ 10 seconds.



Figure 9.89

- Once connection between Lifeguard and the Davey Heat Pump is complete, the confirmation will show (refer Figure 9.90). Click “Done” to return to the dashboard.



Figure 9.90

9.11.2. Connecting Lifeguard to a “Davey by Nirvana” Heat Pump

- If you are looking to sync a “Davey Heat Pump”, go to section 9.11.1 of this manual.
- On your ‘Davey by Nirvana’ heat pump, press the menu button to go into the main menu.
- Use the ▲ up and ▼ down buttons to scroll down to WIFI and press the ► button to confirm.



Figure 9.91

- Select RECONFIGURE WIFI by pressing the ► button.



Figure 9.92

- It will then ask you to confirm or cancel the reconfigure. Use the ▼ down button to move the selection to RECONFIGURE and then press the ◀ button to confirm.



Figure 9.93

- You should see the screen below:



Figure 9.94

- It will then confirm that the RECONFIGURE has been successful and display the MAC address or Heat Pump ID. You will need to write this down.



Figure 9.95

- Open your phone settings and go to the Wi-Fi settings, you will see a Nirvana SSID. Click on this to connect to your heat pump (Figure 9.96).

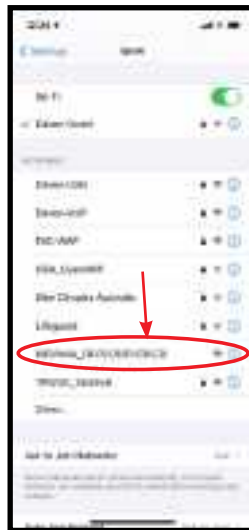

Figure 9.96

- A screen should open from the Nirvana site (Figure 9.97). If it doesn't open automatically, open a web browser manually. Please enter your Wi-Fi SSID or username and password and click connect.



Figure 9.97

- Confirm Nirvana heat pump screen shows:
'RECONFIGURE WIFI SUCESS! CONNECTED TO WEB SERVICE'

- From the dashboard, go to the “settings” menu press the “Heat Pump” button

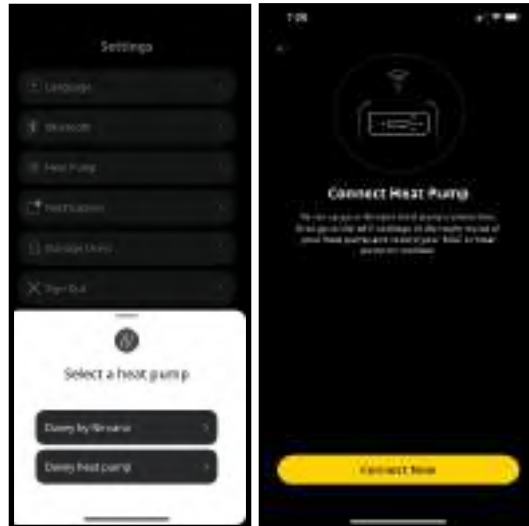

Figure 9.98

- Enter your MAC or heat pump ID in the format shown. Then press “Connect Now”

Note: It is important to enter the MAC or heat pump ID number in this format XX-XX-XX-XX-XX-XX



Figure 9.99

- Once connection between Lifeguard and the Davey by Nirvana heat pump is complete, no confirmation will show, the app will return to the home screen.

9.11.3. Adjusting set temp of Heat pump via Lifeguard

- From the dashboard of the Davey Lifeguard app, press “probe settings” (refer figure 10.0)



Figure 10.0

- With the heater already on, press the button for “Water Temp” “Edit” (refer Figure 10.1).



Figure 10.1

- Ensure that “Probe Connected?” is shown as “YES”, as indicated by yellow highlight (refer Figure 10.2). Adjust to the pool set temperature by scrolling the set point up and down with your finger on the screen.

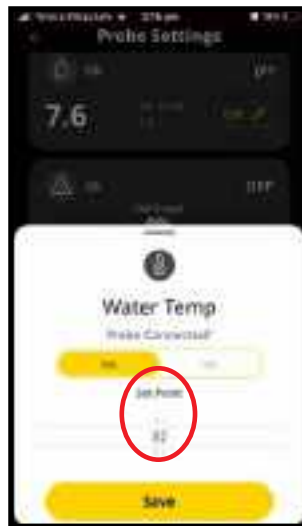

Figure 10.2

- Once you're happy with the change, press "Save" (refer Figure 10.3).



Figure 10.3

- Now the change is reflected in the Probe Settings screen, press the back button to return to the dashboard (refer Figure 10.4).



Figure 10.4

10. GENERAL INFORMATION

10.1 RECOMMENDED POOL WATER LEVELS

POOL WATER BALANCE	Free Chlorine (ppm)	pH	Total Alkalinity TA (ppm)	Calcium Hardness (ppm)	Stabiliser - Cyanuric Acid (ppm)	Recommended salt Levels (ppm)
Ideal reading / range	1.5 - 3	Concrete & tiled pools 7.4-7.6 Other surfaces 7.2-7.4	80 - 150	Concrete & tiled pools 200-275 Other surfaces 100-225	25-50ppm (15-25ppm if used with an ORP controller) Not to be used in indoor pools.	Depends on the model of your Nipper. Consult the installation & operating instructions via www.bit.ly/nippercm
To increase	Increase output of sanitiser. Add chlorine. Increase filtration time.	Add Soda Ash (Sodium Carbonate)	Add Buffer (Sodium Bicarbonate)	Add Calcium Chloride	Add Cyanuric Acid	Add salt
To decrease	Decrease output of sanitiser. Decrease filtration time.	Add Hydrochloric Acid	Add Hydrochloric Acid or Dry Acid	Partially drain & refill pool with lower hardness water to Dilute	Partially drain & refill pool to dilute	Partially drain & refill pool to dilute
Frequency of testing	Weekly	Weekly	Weekly	Weekly	Regularly	Regularly

Figure 10.5

10.2 FACTORS THAT INFLUENCE YOUR POOL WATER CHEMISTRY

10.2.1. Cyanuric Acid:

- Cyanuric Acid (aka Stabiliser as explained in section 3) is used in swimming pools that are exposed to UV, to help retain Chlorine in the water and limit rapid Chlorine breakdown. The recommended cyanuric acid range in most outdoor swimming pools is 25-50ppm.

What is not commonly known is the effect cyanuric acid has on ORP (also defined in section 3). It should be realised that your pool water's ORP can be reduced by an increase of cyanuric acid (refer Figure 10.6).

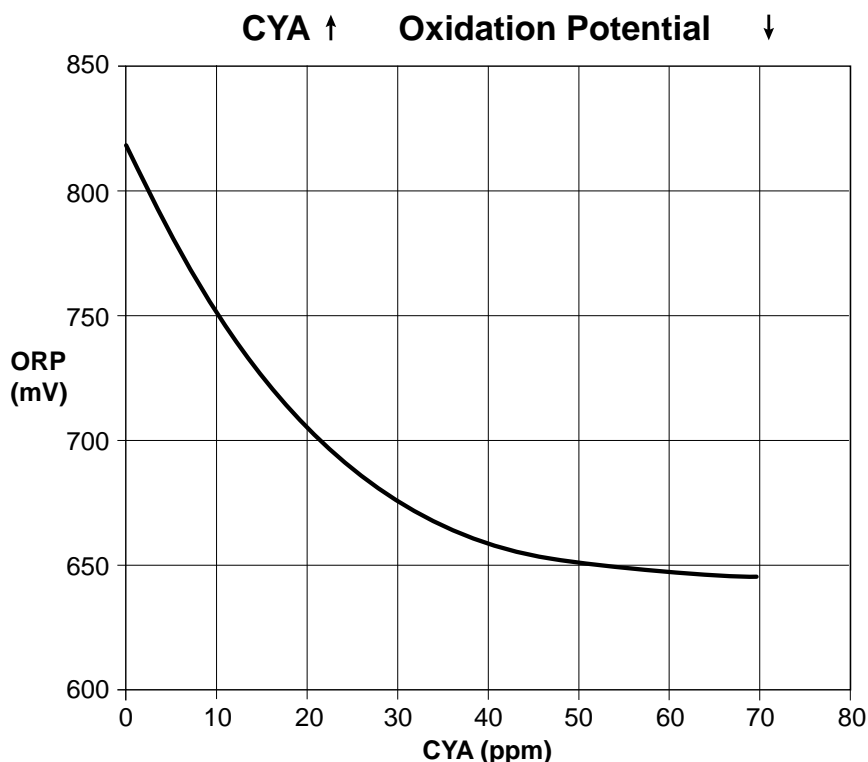

Figure 10.6

This reduction of ORP can be confused by Lifeguard to be a low Chlorine level. In reaction to the perceived low Chlorine level, Lifeguard will increase its Chlorine production (unnecessarily) and elevate the Chlorine level in the pool.

If the stabiliser levels in your pool are higher than 25ppm, Davey recommends adjusting your ORP setpoint down to achieve the correct chlorine level.

- Only adjust in increments of 25mV per day.
- Take water tests after each filtration cycle until the correct chlorine level is reached.
- It is a good idea to regularly check your pool chemistry at your nearest pool shop.

10.2.2. Sodium Bicarbonate:

- Sodium Bicarbonate (aka Buffer as explained in section 3) is used in swimming pools to increase a pool's Total Alkalinity, to assist in the control of pH balance. The recommended Total Alkalinity range in most pools is 80-150ppm.

What is not commonly known is that adding Sodium Bicarbonate to a swimming pool also will also (temporarily) cause pH fluctuations. This "pH bounce" must be acknowledged as it will affect Lifeguard's ability to control pH during the time. It is recommended that immediately after a dose of Sodium Bicarbonate, the pH control side of Lifeguard should be switched off (refer section 8.1). The effect should be considered proportionate to the pool volume and the quantity of Sodium Bicarbonate being added. For example, to add 2kg of Sodium Bicarbonate to a 30,000L pool, it is recommended that the automated pH control be switched off for 24 hours. Similarly, if 4kg of Sodium Bicarbonate is added to a 30,000L pool, it is recommended that the automated pH control be switched off for 48 hours.

11. MAINTENANCE

This section should be read in conjunction with the maintenance section of your ChloroMatic Nipper manual. Refer to www.bit.ly/nippercm

11.1 PROBE DAMAGE

Should one of the probes become damaged, the system needed be completely shut down. During the time it takes to replace the damaged probe(s), simply use the probe blanks in place. This will allow the continued circulation and filtration of your pool water. To fit the probe blanks, follow the relevant part of section 4.



IMPORTANT: Be sure to turn off the probe in the Lifeguard menu, following the relevant part from section 6.

When re-fitting the replacement probe, following the relevant part from section 6.



11.2 WINTERISING THE PROBES

When winterising the pool, if the pool equipment is to be completely switched off, Davey recommends the probes be unplumbed from the pipework and stored in a “winterising solution”. Using the original probe bottles, the salt/conductivity probe should be stored in distilled water. The ORP and pH probes should be winterised in a 3M~3.5M KCl solution.

This solution can be made by dissolving 22g of Potassium Chloride into 100mL of distilled water.

12. TROUBLESHOOTING

12.1 WARNINGS AND ALARMS

Warning or Alarm	Message on Davey Lifeguard	Cause for Alarm	How alarm is cleared
Low Salt Warning	SALT LOW	Low Salt Models - salt reading of 1500ppm or below. Regular Models - salt reading of 3000ppm or below.	Once the Davey Lifeguard registers a salt concentration within range the warning will clear.
Low Salt Alarm	SALT LOW	Low Salt Models - salt reading of 1200ppm or below. Regular Models - salt reading of 2500ppm or below.	Once the Davey Lifeguard registers a salt concentration within range the alarm will clear and the Davey Lifeguard will return to normal operation.
Check Pool Chem Alarm	CHECK POOL CHEM	Dirty cell or inaccurate pool chemistry.	Cell will have turned off. Check cell is clean and clean if required. Have a full analysis of water done and make sure that all parameters are within the recommended range in the table (Figure 10.1 next page). Press the SELECT button to clear the alarm.
WiFi Disconnected Warning	Flashing icons  	Davey Lifeguard is disconnected from WiFi.	Davey Lifeguard will attempt to re-connect itself to WiFi. If this does not happen automatically press and hold the SELECT button for 5 seconds and until both icons will toggle to re-establish internet connection. Connection is established when both icons are stable.
pH Low Warning	PH LOW	If a pH reading is great than or equal to 0.2pH units less than set point is recorded.	Will clear automatically once pH is within 0.2pH units away from set point.
pH Low Alarm	PH LOW	If a pH reading of 6.8 or below is recorded.	Will clear automatically once pH is raised above 6.8.
pH High Warning	PH HIGH	If a pH reading greater than or equal to 0.2pH points more than set point is recorded.	Will clear automatically once pH is within 0.2pH units away from set point.
pH High Alarm	PH HIGH	If a pH reading of 8 or above is recorded.	Will clear automatically once pH is below 8.
ORP Low Warning	ORP LOW	If an ORP reading greater than or equal to 100mV points less than set point is recorded.	Will clear automatically once ORP is within 15mV of set point.
ORP High Warning	ORP HIGH	If ORP reading is greater than or equal to 100mV more than set point.	Will clear automatically once ORP is within 15mV of set point.
ORP High Alarm	ORP HIGH	If the ORP reading of 1,000mV or higher is recorded.	Will clear automatically if once ORP reading is lower than 1,000mV.
ORP Low Alarm	ORP LOW	If an ORP reading is 335mV or below.	Will clear automatically once ORP is above 335mV.
Low Flow Alarm	FLOW LOW	A flow rate below 80L/min.	Fault is cleared instantly and automatically once correct flow is detected.
Setup Incomplete	SETUP INCOMPLETE	The first time set-up process was not completed.	Select FACTORY RESET and complete the process.

Check ORP Probe	CHECK ORP PROBE	ORP probe is measuring unexpected results.	Check that the ORP probe is properly installed, perform a recalibration. You may need to replace the probe.
Check ORP Probe	CHECK ORP PROBE	pH probe is measuring unexpected results.	Check that the pH probe is properly installed, perform a recalibration. You may need to replace the probe.
VSD Fault	VSD FAULT	The VSD pump has an error.	Refer to your VSD Installation and operating instructions to diagnose the fault.

ADDITIONAL INFORMATION:

LED = solid is a warning, = flashing is an alarm

Clearing probe alarms are done automatically when readings are within limits.

Probe alarms are triggered only if there is flow, and will remain on until cleared

12.2 RECOVERING DRY PROBES

Should one of the probes dry out the following method should be followed:

1. Remove the probe from the manifold and place in a probe cleaning solution for 15-20 minutes
2. Remove probe from cleaning solution and rinse thoroughly in deionized/distilled water.
3. Place probe in a storage solution for at least 1 hour (can be left overnight).
4. Remove probe from storage solution and rinse thoroughly with deionized/distilled water.
5. Recalibrate probe and return to manifold, if calibration is successful, if unsuccessful the probe must be replaced.

12.3 ADDITIONAL TIPS

Note:

- Always double check any abnormal probe readings with a pool chemistry test.
- Always ensure your Lifeguard is connected to Wifi when troubleshooting connectivity concerns. This can be checked via the Lifeguard dashboard (refer Figure 12.1).



Figure 12.1

Pool pH is high but the probe is showing normal

- Check that the setpoint of your pH level isn't set too high.
- The probe may need recalibration, please follow the instructions in your manual to recalibrate the probe. You should recalibrate each of your probes every 3 months to maintain accuracy. If the problem isn't resolved you may need to replace the probe.

Pool chlorine is high but the probe is showing normal or low ORP

- Check that the setpoint of your ORP level isn't set too high. Your ORP may need to be adjusted down.
- The probe may need recalibration, please follow the instructions in your manual to recalibrate the probe. You should recalibrate each of your probes every 3 months to maintain accuracy. If the problem isn't resolved you may need to replace the probe.
- Pool chemistry levels such as pH, alkalinity and stabiliser/cyanuric acid levels will affect your ORP reading. If a pool test shows that their levels are outside of the recommended range you will need to ignore/disconnect your ORP probe using the app or at the Lifeguard unit and correct the levels of the other chemistry. If your stabiliser/cyanuric acid levels remain out of range, adjust your ORP setpoint down to compensate when the probe is reconnected and recalibrated.

Pool chlorine is low but the probe is showing normal ORP

- Check that the setpoint of your ORP level isn't set too low. Your ORP may need to be adjusted up.
- The probe may need recalibration, please follow the instructions in your manual to recalibrate the probe. You should recalibrate each of your probes every 3 months to maintain accuracy. If the problem isn't resolved you may need to replace the probe.

Pool salt is low but the probe is reading normal/high TDS

- The probe may need recalibration, please follow the instructions in your manual to recalibrate the probe. You should recalibrate each of your probes every 3 months to maintain accuracy. If the problem isn't resolved you may need to replace the probe.
- The low salt models of the Davey Lifeguard and Nipper are designed to operate down to 1500ppm TDS, check if you have a low salt model.
- Add more salt to increase it to within the recommended levels.

Pool salt is normal but the probe is reading a lower TDS

- Check that the Salt probe is installed correctly and in the correct position in the manifold.
- Check that the probe lead is correctly connected into the back of the Lifeguard and is in the correct position.
- The probe may need recalibration, please follow the instructions in your manual to recalibrate the probe. You should recalibrate each of your probes every 3 months to maintain accuracy. If the problem isn't resolved you may need to replace the probe.

Pool salt is normal but the Lifeguard has a low salt alarm

- Your electrolytic cell may require cleaning. Please refer to your Nipper instructions on how to clean your cell.
- Check that the Salt probe is installed correctly and in the correct position in the manifold.
- Check that the probe lead is correctly connected into the back of the Lifeguard and is in the correct position.
- The probe may need recalibration, please follow the instructions in your manual to recalibrate the probe. You should recalibrate each of your probes every 3 months to maintain accuracy. If the problem isn't resolved you may need to replace the probe.

If calcium levels in the pool are high, you will notice more build up on your electrolytic cell and more instances of a low salt alarm. For these applications, it's possible to change your polarity reversal time to help clear the build up.

- Enter the service mode from the main menu
- Passcode is 1234
- Change the reversal time for your cell

Regular cleaning will still be required to maintain the cell and prolong life.

Probe is reading low or negative levels

- Check that the probes are installed correctly and in the correct position in the manifold.

- Check that the probe lead is correctly connected into the back of the Lifeguard and is in the correct position.
- The probe may need recalibration, please follow the instructions in your manual to recalibrate the probe. You should recalibrate each of your probes every 3 months to maintain accuracy. If the problem isn't resolved you may need to replace the probe.

Pool pH is not adjusting itself

- Check that your pH probe is correctly reading the pH levels, you may need to recalibrate the probe.
- Check that your acid drum is not empty and your feeder tubes haven't been blocked or broken. Please follow the instructions for the acid pump if you require changing the tubes.
- Check that your pH pump is connected in the back of the lifeguard unit.
- Your acid pump will not run if the pH exceeds 9.0, manually add acid to your pool to bring the level down and ensure all other chemistry levels are within recommended levels.
- If your acid pump will still not run you may need to replace it, this is available as a spare part from Davey.
- Your unit may need repair, please call your nearest Davey pool dealer

Lifeguard is not maintaining the chemical levels

- Make sure your schedule is set for enough time to allow for the lifeguard to reach the setpoints.

Note: Always have your schedule set to allow for the pool volume to turnover 2 times per day. This will ensure that the Lifeguard has sufficient time to maintain your pH and Chlorine levels.

pH pump is running continuously

- Make sure your acid probe is correctly connected to your lifeguard.
- If it is not connected, reconnect or follow the instructions in the manual to ignore the probe.
- The probe may need recalibration, please follow the instructions in your manual to recalibrate the probe. You should recalibrate each of your probes every 3 months to maintain accuracy. If the problem isn't resolved you may need to replace the probe.

No power to Lifeguard

- Check that the IEC plug in the back of the lifeguard is inserted properly and secured through the cable retention feature.
- Check that the power to your power outlet is switched on
- Your unit may need repair, please call your nearest Davey pool dealer

Nipper is not connected to lifeguard

- If your Nipper chlorinator is not displaying Lifeguard on the screen check that the RJ45 cable is connected from the back of your Nipper to your Lifeguard.
- Check the (nipper symbol) on your lifeguard is solid.
- Lifeguard will need to be powered before the Nipper on first time start up.
- EU only - Lifeguard should be always powered, the Ecosalt2 should be run on a timer/schedule.
- It may be necessary to force a software update – make sure your lifeguard is connected to wifi then hold the down button on your lifeguard down until the screen goes blank, it will update your lifeguard to the latest version. Once complete, hold the back button down until the screen goes blank, this will update your Nipper chlorinator.
- Your unit may need repair, please call your nearest Davey pool dealer

Lifeguard is showing low flow alarm

- If your pump is running check that the set speed is high enough for your pool installation, you may need to increase the speed.
- Ensure any valves including the filter multiport valve is set to the correct position.
- Check that your flow sensor isn't jammed off and is free from any debris and is in the correct flow direction.
- Check that your pump is plugged into your nipper chlorinator (or power outlet).

- Check that your nipper is being powered (au) – the screen should read LIFEGUARD.
- You may need to Backwash your sand filter to reduce the flow restriction.

Lifeguard is showing low salt alarm

- Check that your salt levels are in range.

Lifeguard screen is black

- If your unit is in direct sunlight this can occur.
- Screen should return to normal when cool.
- Install shade or move unit out of direct sunlight.

Lifeguard screen is blank

- Ensure there is power to the unit.
- Try resetting the lifeguard by disconnecting and reconnecting the power to the unit.
- Your unit may need repair, please call your nearest Davey pool dealer

Clicking sound coming from Nipper Chlorinator

- This usually indicates that the flow is a bit too low for your installation and the flow switch is not staying on consistently. Increase the speed on your pump to correct the problem.
- You may need to Backwash your sand filter to reduce the flow restriction.

I cannot connect to wifi

- Check that your home wi-fi is working and you have a full strength wi-fi signal at your pool equipment installation (refer Section 7).
- You may need to install a wi-fi extender to boost the signal to that area.
- Check that your antenna is properly installed on your lifeguard unit.
- (make sure your wifi password isn't over 20 characters) if issue isn't fixed

13. SPARE PARTS

13.1 EXPLODED DIAGRAM

Lifeguard	DCLGAU	DPLGEU
------------------	---------------	---------------

Notes: A. DPLGEU available exclusively in Europe.
 B. DCLGAU available exclusively in Australia & New Zealand

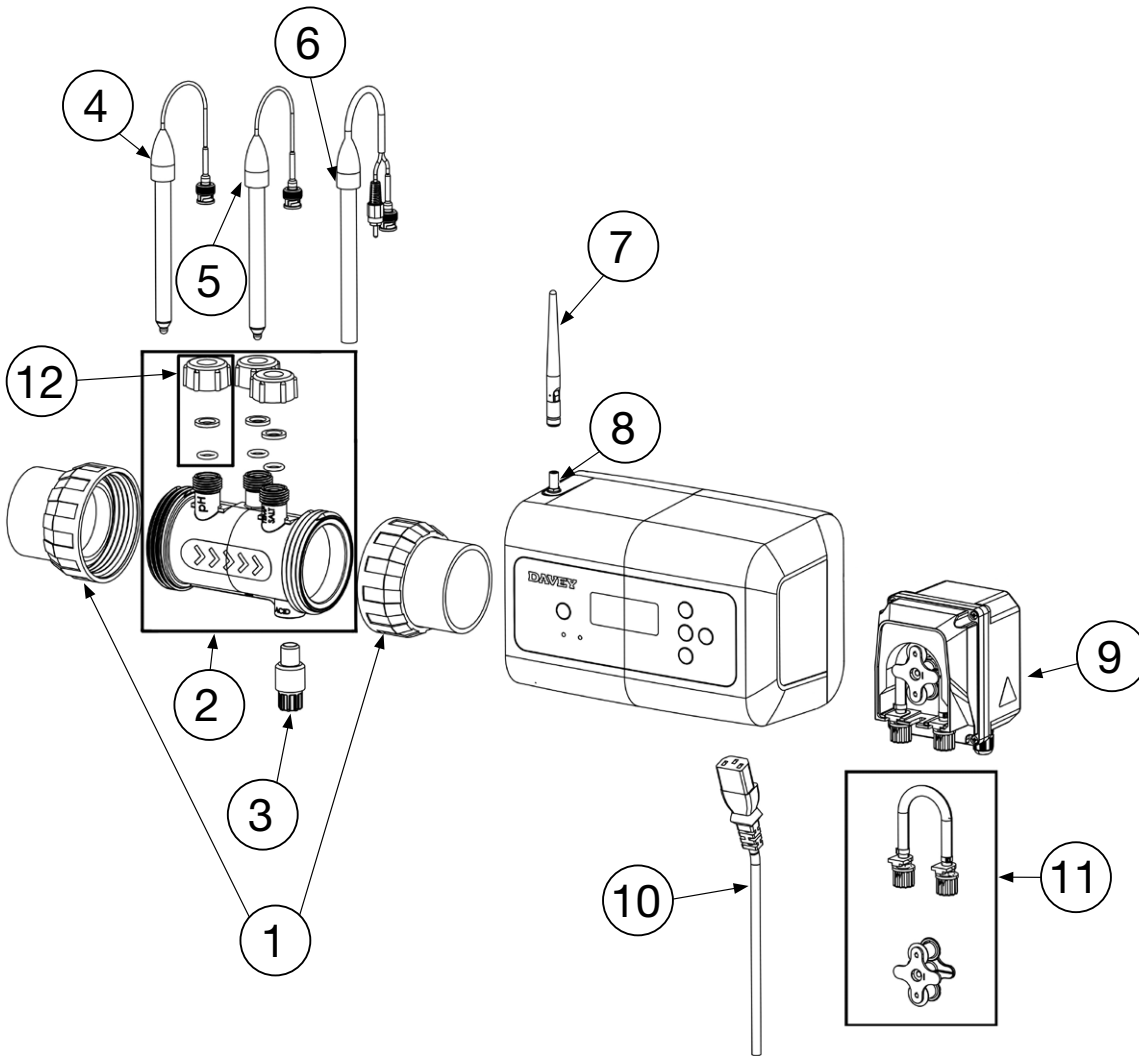

ITEM	PART NO.	DESCRIPTION	NOTE	QTY REQ'D
1	48722B-1SP	Barrel union assyEU63mm O-ring	A	2
1	48722BSP	Barrel union assyAU50mm O-ring	B	2
2	33086SP	Probe and injector housing w probe seal kit x 3		1
3	9900071016SP	Acid injection point		1
4	16166SP	lifeguard pH probe		1
5	16167SP	Lifeguard ORP probe		1
6	16168SP	Lifeguard Temp sensor & TDS probe		1
7	403621SP	Lifeguard std. Antenna		1
8	33079SP	Lifeguard controller c/w antenna		1
9	16141SP	Acid dosing pump		1
10	403370SP	Power supply lead - DCLGAU	B	1
10	403371SP	Power supply lead - DPLGEU	A	1
11	33134SP	Acid pump tube service kit incl. roller, all tube		1
12	33132	Probe seal kit		3
-	403393SP	Reducing bush - DPLGEU	B	2
-	33133SP	Probe calibration solution kit w 3 x pH and ORP 1 x TDS		1
-	16207SP	Lifeguard pump cable 3m		1
-	16142SP	RJ45 connection cable nipper		1
-	9900106162SP	Acid pump suction filter & weight		1
-	RIC0151303SP	Clear face plate pH pump		1

Davey Warranty

Davey Water Products Pty Ltd (Davey) warrants all products sold will be (under normal use and service) free of defects in material and workmanship for a minimum period of one (1) year from the date of original purchase by the customer as marked on the invoice, for specific warranty periods for all Davey products visit daveywater.com.

This warranty does not cover normal wear and tear or apply to a product that has:

- been subject to misuse, neglect, negligence, damage or accident
- been used, operated or maintained other than in accordance with Davey's instructions
- not been installed in accordance with the Installation Instructions or by suitably qualified personnel
- been modified or altered from original specifications or in any way not approved by Davey
- had repairs attempted or made by other than Davey or its authorised dealers
- been subject to abnormal conditions such as incorrect voltage supply, lightning or high voltage spikes, or damages from electrolytic action, cavitation, sand, corrosive, saline or abrasive liquids,

The Davey warranty does not cover replacement of any product consumables or defects in products and components that have been supplied to Davey by third parties (however Davey will provide reasonable assistance to obtain the benefit of any third-party warranty).

To make a warranty claim:

- If the product is suspected of being defective, stop using it and contact the original place of purchase. Alternatively, phone Davey Customer Service or send a letter to Davey as per the contact details below
- Provide evidence or proof of date of original purchase
- If requested, return the product and/or provide further information with respect to the claim. Returning the product to the place of purchase is at your cost and is your responsibility.
- The warranty claim will be assessed by Davey on the basis of their product knowledge and reasonable judgement and will be accepted if:
 - a relevant defect is found
 - the warranty claim is made during the relevant warranty period; and
 - none of the excluded conditions listed above apply
- The customer will be notified of the warranty decision in writing and if found to be invalid the customer must organise collection of the product at their expense or authorise its disposal.

If the claim is found to be valid Davey will, at its option, repair or replace the product free of charge.

The Davey warranty is in addition to rights provided by local consumer law. You are entitled to a replacement or refund for a major failure and compensation for any other reasonably foreseeable loss or damage. You are also entitled to have the goods repaired or replaced if the goods fail to be of acceptable quality and the failure does not amount to a major failure.

For any internet connected products the consumer is responsible for ensuring a stable internet connection. In the event of a network failure the consumer will need to address the concern with the service provider. Use of an App is not a substitute for the User's own vigilance in ensuring the product is working to expectation. Use of a Smart Product App is at the User's own risk. To the fullest extent permitted by law Davey disclaims any warranties regarding the accuracy, completeness or reliability of App data. Davey is not responsible for any direct or indirect loss, damage or costs to the User arising from its reliance on internet connectivity. The User indemnifies Davey against any claims or legal actions from them or others relying on internet connectivity or App data may bring in this regard.

Products presented for repair may be replaced by refurbished products of the same type rather than being repaired. Refurbished parts may be used to repair the products. The repair of your products may result in the loss of any user-generated data. Please ensure that you have made a copy of any data saved on your products.

To the fullest extent permitted by law or statute, Davey shall not be liable for any loss of profits or any consequential, indirect or special loss, damage or injury of any kind whatsoever arising directly or indirectly from Davey products. This limitation does not apply to any liability of Davey for failure to comply with a consumer guarantee applicable to your Davey product under local laws and does not affect any rights or remedies that may be available to you under local laws.

For a complete list of Davey Dealers visit our website (daveywater.com) or call:

DAVEY

Davey Water Products Pty Ltd
Member of the GUD Group
ABN 18 066 327 517

daveywater.com

AUSTRALIA

Head Office

6 Lakeview Drive,
Scoresby, Australia 3179
Ph: 1300 232 839
Fax: 1300 369 119
Email: sales@davey.com.au

NEW ZEALAND

7 Rockridge Avenue,
Penrose, Auckland 1061
Ph: 0800 654 333
Fax: 0800 654 334
Email: sales@dpw.co.nz

NORTH AMERICA

Ph: 1-888-755-8654
Email: info@daveyusa.com

MIDDLE EAST

Ph: +971 50 6368764
Fax: +971 6 5730472
Email: info@daveyuae.com

EUROPE

7 rue Eugène Hénaff 69200
Vénissieux, France
Ph: +33 (0) 4 72 13 95 07
Fax: +33 (0) 4 72 33 64 57
Email: info@daveyeurope.eu